

REVISIONS			
REV	DESCRIPTION	DATE	APP'D

NOTE 1: CONNECT THE SHIELD TO THE ENCLOSURE CLOSE TO THE CONDUIT ENTRY POINT.

NOTE 2: CUT THESE WIRES OFF CLOSE TO THE END OF THE CABLE JACKET.

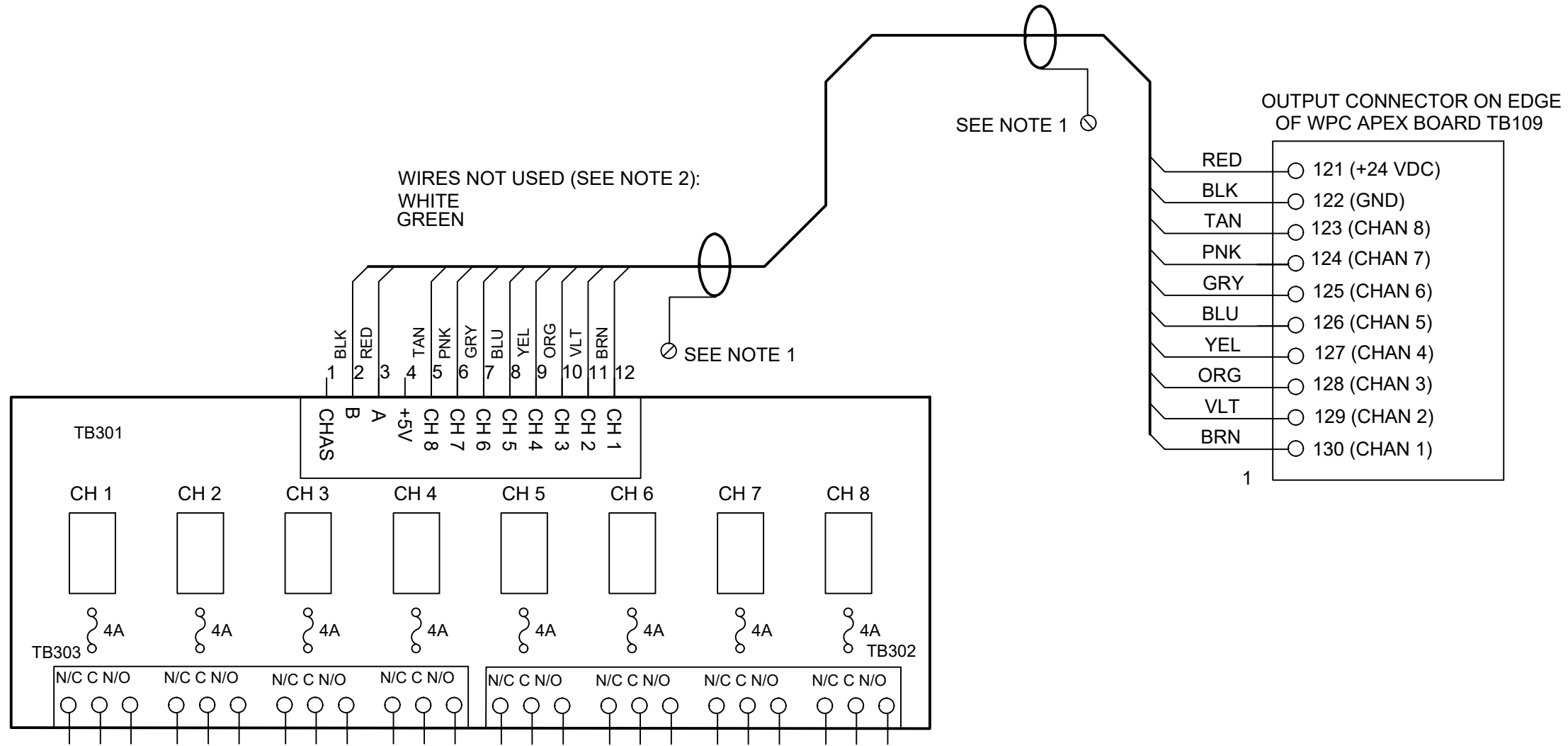

THE CUSTOMER CONNECTS THE ANCILARY EQUIPMENT TO THESE RELAY OUTPUT TERMINALS.

DRAWN	JOC	DATE	2/4/26		
CHK.			WINTRISS CONTROLS GROUP		
APPROVALS		TITLE			
ENG.		WPC APEX CAM OUTPUT WIRING			
MFG.		CODE IDENT NO.	SIZE	DRAWING NUMBER	REV
FILENAME			B	FIGURE 6	
REL		SCALE	SHEET OF		