

| REVISIONS |             |      |       |
|-----------|-------------|------|-------|
| REV       | DESCRIPTION | DATE | APP'D |
|           |             |      |       |

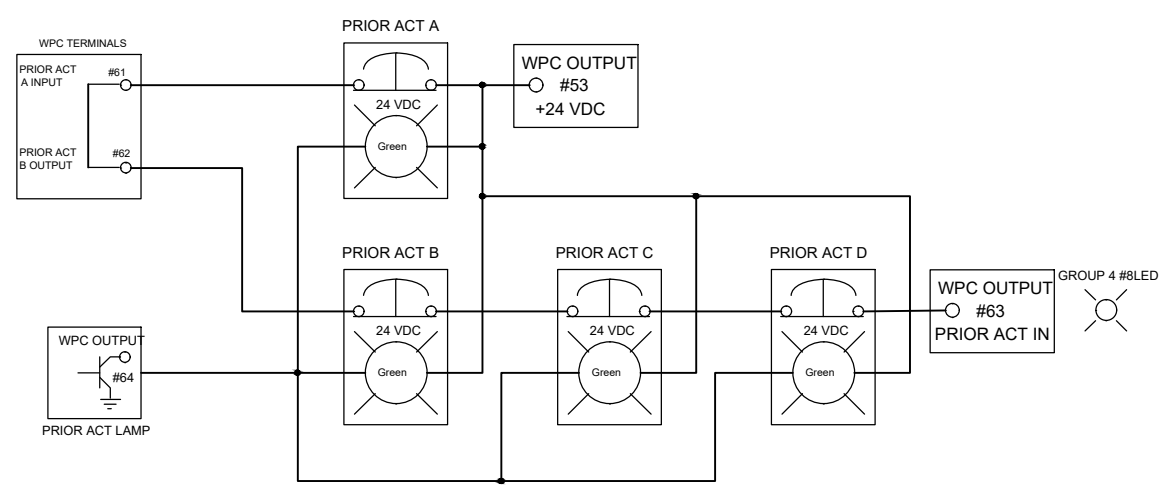
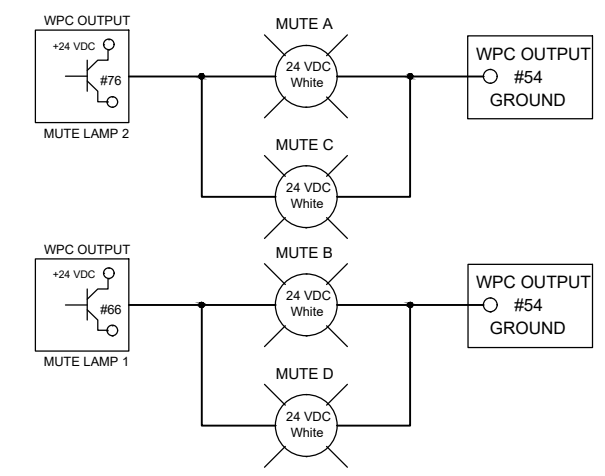
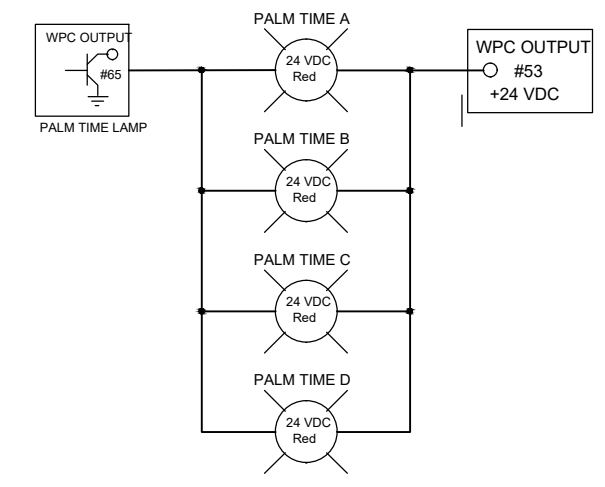
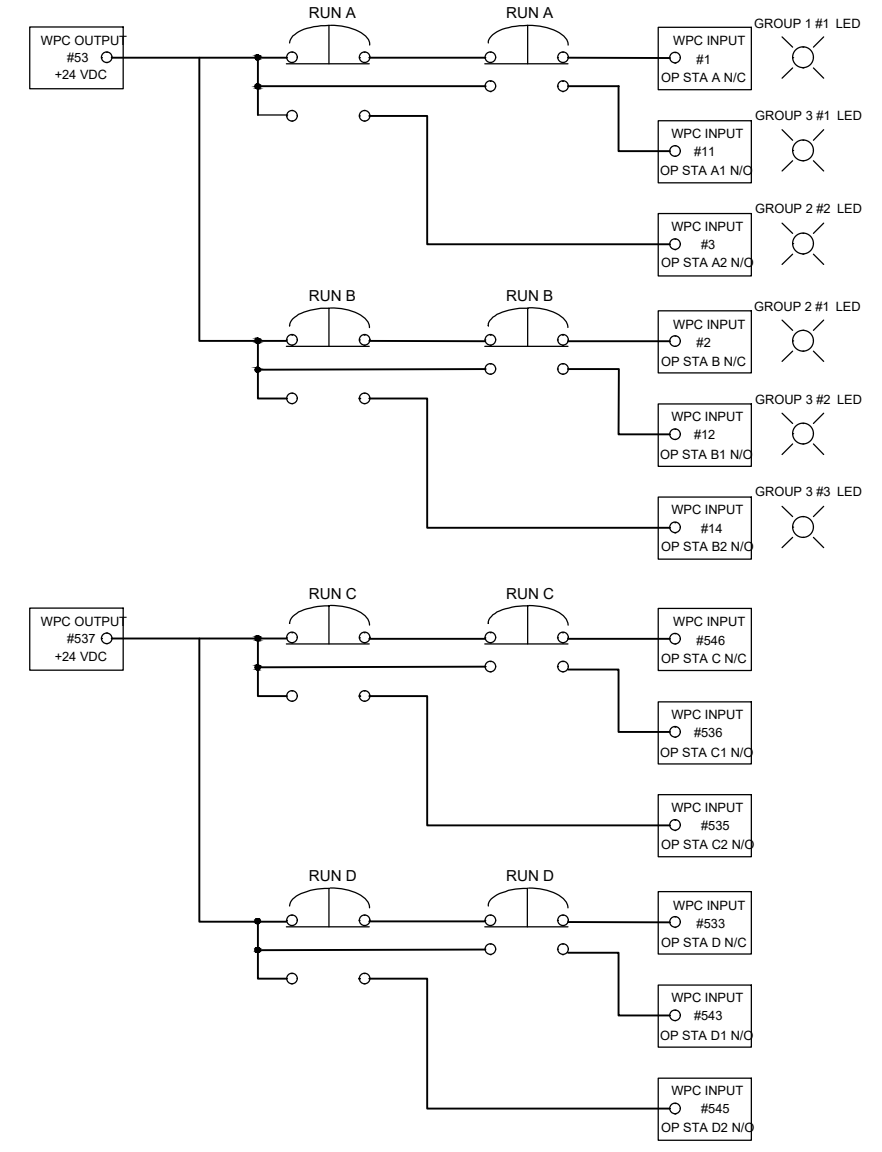
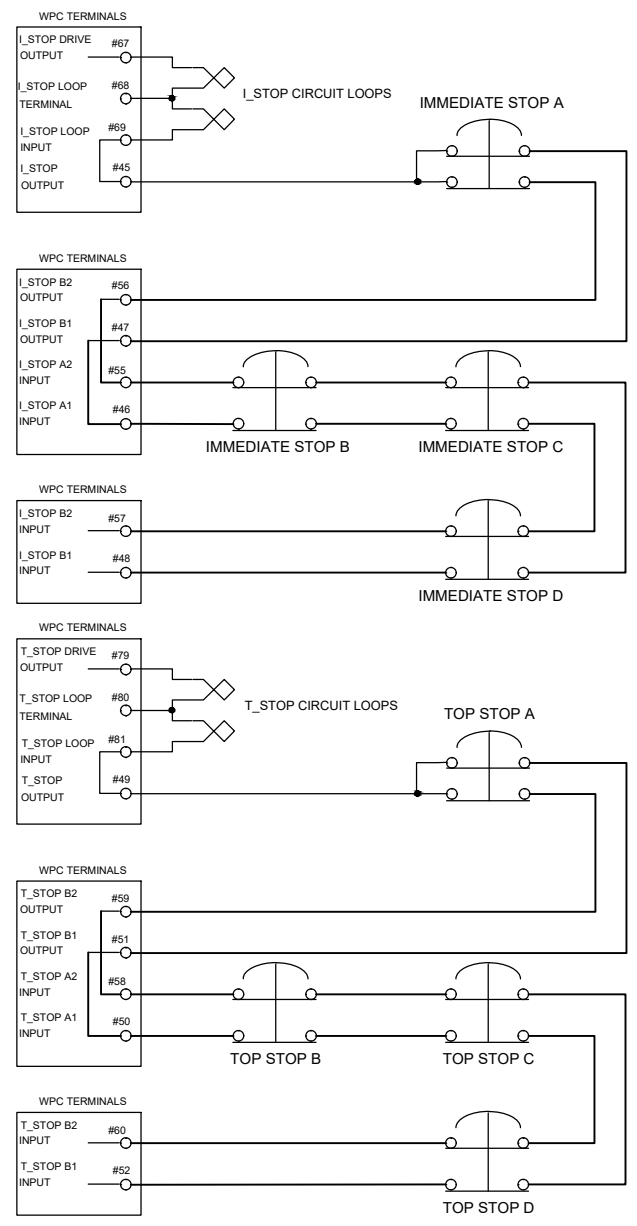

|           |     |      |         |                               |      |                |     |
|-----------|-----|------|---------|-------------------------------|------|----------------|-----|
| DRAWN     | RMB | DATE | 1/23/26 | WINTRISS CONTROLS GROUP       |      |                |     |
| CHK.      | DJD | DATE | 1/23/26 |                               |      |                |     |
| APPROVALS |     |      |         | TITLE                         |      |                |     |
|           |     |      |         | WPC APEX OEM OPERATOR STATION |      |                |     |
| ENG.      |     |      |         | CODE IDENT NO.                | SIZE | DRAWING NUMBER | REV |
| MFG.      |     |      |         |                               | B    | FIGURE 24      |     |
| FILENAME  |     |      |         |                               |      |                |     |
| REL       |     |      |         | SCALE                         | NONE | SHEET          | OF  |