

SmartPAC **PRO**

Wintriss® Press Automation Control

1143200

Rev. E March 2024

Installation Manual



Wintriss Controls Group, LLC
100 Discovery Way
Unit 110
Acton MA 01720 USA
Phone (800) 586-8324
Fax (978)263-2048

Tech Support Hotline 800-586-8324 8-5 Eastern

Thank you for purchasing a Wintriss product. We appreciate your business and want to do whatever we can to ensure your satisfaction. Wintriss products are built to stay on the job day after day, and are backed by an ironclad guarantee, international standards approvals, and unbeatable support. Whenever you need assistance or service, we back all our products with excellent spare parts inventories, training programs, and prompt repair service. We would like to share with you a list of service options – probably the largest number of service options offered in the industry.

- **Technical Assistance**

We offer a toll-free line for technical assistance. Call our Wintriss Technical Support Hotline at 1-800-586-TECH (8324) should you have any questions about your equipment. Our technical staff is ready to assist you Monday through Friday, 8 a.m. to 5 p.m. Eastern Time. In many cases our experienced technical staff can resolve your inquiry right over the phone.

- **Return Authorization**

Please call our 800 number for a return authorization (RMA) number to return a product for repair. Returned goods must arrive freight prepaid. In order to process your return quickly, we ask that you provide us with the following pertinent information when you call: purchase order number, shipping address, contact name and telephone number, and product type. The assigned RMA number should appear on all packages returned to Wintriss Controls Group to ensure prompt service.

At the time of requesting an RMA, you will be quoted a flat-rate repair price for the product you are returning. We ask that you email a PO to orders@wintriss.com for that amount or enclose the PO with the returned item. This will enable us to ship the item back to you as soon as the repair has been completed. If the item cannot be repaired or there are additional charges, you will be contacted for approval.

Please be sure to carefully pack all returned items and ship to our Acton, MA location.

- **Expedited Repair Program**

Rush service providing 48 hour turnaround is available for most products upon request. An Expedite Fee will be applied to our standard repair rate.

- **Board Exchange Program**

If your needs are urgent, you can take advantage of our Board Exchange (EX) program. Call our 800 number between 8 a.m. and 3:30 p.m. Eastern time and we will send a replacement to you overnight. A fee does apply to this service. Contact Wintriss Technical Support at 800-586-8324 for details.

- **Service Center**

Our Service Center for product service is located at our headquarters in Acton, MA. If your equipment requires repair, please contact us at 800-586-8324 to obtain a return authorization number. Nationwide field service is also available. Contact the Wintriss Technical Support group at 800-586-8324.

- **Product Training**

We also offer both product training and maintenance/troubleshooting courses at our Acton, MA and Chicago-area facilities. On-site training is available from the factory or through your local Wintriss representative.

- **Restocking Charge**

Returned goods are subject to a 20% restocking charge if returned for credit. The minimum charge is \$50, not to exceed \$250 per item.

Whatever the product, we are committed to satisfying you with innovative engineering, quality construction, reliable performance, and ongoing, helpful support. Call us whenever you need assistance.

Table of Contents

| | |
|--------------------------------------------------------------------------------------|-----------|
| Chapter 2 – Installing SmartPAC PRO | 15 |
| Before You Start | 16 |
| Installation Guidelines | 17 |
| Terminating Cable Shields | 18 |
| Checking the Press | 18 |
| Mounting the SmartPAC PRO Control Enclosure..... | 19 |
| Installing SmartPAC PRO as a Panel Mount..... | 20 |
| Installing SmartPAC PRO in a Pendant..... | 22 |
| Installing the Resolver | 22 |
| Mounting the Resolver | 24 |
| Wiring the Resolver..... | 25 |
| Connecting Power Wiring – AC Powered Units | 26 |
| Connecting Power Wiring – 24 VDC Powered Units..... | 28 |
| Connecting Stop Circuits and Input Check Circuit..... | 28 |
| Making Wiring Connections..... | 28 |
| Setting the Input Check Voltage Switch | 29 |
| Adding or Upgrading DiProPAC or ProCamPAC Option..... | 31 |
| Connecting DiPro Sensor Interface to SmartPAC PRO | 33 |
| Connecting ProCamPAC Programmable Cam Channels..... | 37 |
| Wiring Setup Mode Circuit..... | 44 |
| Wiring a Remote Reset Switch (Optional) | 44 |
| Wiring a Sensor-Disabled Output (Optional) | 44 |
| Wiring the ProCamPAC Output with Your Mechanical Top Stop Cam Switch (Optional)..... | 45 |
| Zeroing the Resolver..... | 46 |
| Turning on Power to SmartPAC PRO | 46 |
| Verifying Installation of DiProPAC and/or ProCamPAC (Optional)..... | 47 |
| Moving the Ram to Top Dead Center (TDC) | 48 |
| Setting the Resolver Zero Position | 48 |
| Installing the Position Sensor (Optional)..... | 49 |
| Final Checkout..... | 53 |
| Set Up a “Test” Tool | 53 |
| Check and Set Direction of Rotation of Resolver | 53 |
| Check for Position Sensor (If Installed) Error Messages | 53 |
| Check the Top-stop Circuit | 53 |
| Check the Emergency-stop Circuit..... | 54 |
| Check Cam Channels (ProCamPAC Only)..... | 54 |
| Test Complete..... | 54 |
| What Next? | 54 |
| Wiring Tables for Other SmartPAC PRO Connections..... | 55 |

| | |
|-------------------------------------------------------------------------------------|-----------|
| Chapter 8 – SmartPAC PRO Fault Messages | 57 |
| Responding to the Brake Warning LED | 57 |
| Responding to Fault Messages | 57 |
| Counter Preset Reached Messages | 58 |
| “S03 Good parts counter preset reached TS” | 58 |
| “S06 Strokes counter preset reached TS” | 58 |
| “S0x Batch # counter preset reached TS” | 59 |
| Messages for Equipment or Brake Monitor Problems | 59 |
| “S11 Loss of rotation ES” | 59 |
| “Angle resolver failure” | 60 |
| “S12 Input check circuit failure” | 60 |
| “S10 Position sensor incorrect ES” | 60 |
| E-Stop errors | 61 |
| “Inboard ram test failure” | 61 |
| “Resolver signals incorrect” or “Resolver drive signal incorrect” | 61 |
| “S13 Stop time exceeded” | 62 |
| Messages for Programming Problems | 63 |
| “No tool number has been loaded” | 63 |
| “S09 Tool number table checksum error ES” | 63 |
| “S30 Program memory checksum 1 fault” | 64 |
| “S31 Program memory checksum 2 fault” | 64 |
| Messages for Sensor Faults | 64 |
| “Green sensor missed” | 64 |
| “Green sensor actuated late” | 64 |
| “Green sensor failure” | 65 |
| “Green constant fault” | 65 |
| “Green quick check sensor actuated outside ready” | 65 |
| “Green special fault” | 65 |
| Fault message for yellow sensors “This N/O sensor is grounded” | 66 |
| Fault message for red sensors “This N/C sensor is open” | 66 |
| Miscellaneous Fault Messages | 66 |
| “S00 Maximum press speed exceeded” | 66 |
| “S01 Minimum press speed exceeded” | 66 |
| “S33 The resolver position is different from when the unit was turned off ES” | 66 |
| “One of the sensor auto enable counters is greater than 99” | 67 |
| “S32 Module communications fault” | 67 |
| “S35 Loss of Communication at Address X ES” | 67 |
| CAN Bus Fault Message | 68 |
| No CAN Connection Detected | 68 |
| Additional Miscellaneous Fault Codes | 68 |
| Troubleshooting Using the Error/Event Log | 68 |

Setup Sheets

SmartPAC PRO Setup Sheet

ProCamPAC Cam Switch – SmartPAC PRO Setup Sheet Channels 1-8

ProCamPAC Cam Switch – SmartPAC PRO Setup Sheet Channels 9-16

DiProPAC Die Protection – SmartPAC PRO Setup Form Sensors 1-16

DiProPAC Die Protection – SmartPAC PRO Setup Form Sensors 17-32

Wiring Diagrams

Figure 1. DiProPAC Sensors 1-16 to DSI 2 Wiring Diagram

Figure 2. DiProPAC Sensors 17-32 to DSI 2 Wiring Diagram

Figure 3. ProCamPAC 16 to Cam Output Wiring Diagram

Figure 4. 120-240 VAC SmartPAC PRO Wiring Configuration

Figure 5. SmartPAC PRO Loopback Test Wiring

Figure 6. 24 VDC SmartPAC PRO Wiring Configuration

Figure 7. 120-240 VAC SmartPAC PRO with USB Extended Wiring Configuration

Figure 8. 24 VDC SmartPAC PRO with USB Extended Wiring Configuration

Figure 9. 120-240VAC SmartPAC PRO with Remote RTS Wiring Configuration

Figure 10. 120-240 VAC SmartPAC PRO Wiring Configuration w/ CAN Bus

Figure 11. +24 VDC SmartPAC PRO Wiring Configuration with CAN Bus

Figure 12. 120 – 240 VAC SmartPAC PRO with CAN Bus and Remote RTS Wiring Configuration

Figures

| | |
|---------------------------------------------------------------------------------------------------------------|----|
| Figure 2-1. SmartPAC PRO Mounting Dimensions | 19 |
| Figure 2-2. SmartPAC PRO Panel Mount Cutout Dimension | 20 |
| Figure 2-3. SmartPAC PRO Panel Mount Dimensions..... | 21 |
| Figure 2-4. Pendant Installation | 22 |
| Figure 2-5. Resolver Dimensions | 23 |
| Figure 2-6. Location of Terminal Blocks TB1 through TB8..... | 23 |
| Figure 2-7. Wiring AC to Terminal Block, Inside Enclosure, Top Right | 27 |
| Figure 2-8. Schematic of Input Check Circuit for 10-130 Vac or Vdc | 28 |
| Figure 2-9. Input Check Voltage Switch (S101) in the Factory Default (60-250V) Position | 30 |
| Figure 2-10. Location of Serial Number on SD Card (HMI Board) | 30 |
| Figure 2-11. SmartPAC PRO Main (RTS) Board Showing Location of Option Module Boards, and TB3 and TB4 | 32 |
| Figure 2-12. DiProPAC Boards (8-, 16-, and 32-Sensor): Location of Components..... | 33 |
| Figure 2-13. ProCamPAC Boards (8- and 16-Channel): Location of Components | 39 |
| Figure 2-14. ProCamPAC Output Assembly | 40 |
| Figure 2-15. Installing Suppressors Across an AC Load | 43 |
| Figure 2-16. Installing a Diode Across a DC Load | 43 |
| Figure 2-17. Optional Top-Stop Wiring..... | 45 |
| Figure 2-18. Main Program Menu..... | 47 |
| Figure 2-19. Installed Options Screen (yours may list different options) | 48 |
| Figure 2-20. “Resolver Zero” Screen | 49 |
| Figure 2-21. Position Sensor Dwell on Different Diameter Shafts | 50 |
| Figure 2-22. Position Sensor Screen | 51 |

| | |
|-------------------------------------------------|----|
| Figure 2-23. Position Sensor Installation | 52 |
| Figure 8-1. Error Code Message | 57 |
| Figure 8-2. Counter Preset Message | 58 |
| Figure 8-3. Location of JP101..... | 62 |

Tables

| | |
|----------------------------------------------------------------------------------------|----|
| Table 2-1. Resolver Wiring..... | 26 |
| Table 2-2. Stop and Input Check Circuit Wiring Connections: TB4 | 29 |
| Table 2-3. DiPro Sensor Interface (DSI) 2 to SmartPAC PRO Wiring, Sensors 1-8 | 34 |
| Table 2-4. DiPro Sensor Interface (DSI) 2 to SmartPAC PRO Wiring, Sensors 9-16 | 35 |
| Table 2-5. DiPro Sensor Interface (DSI) 2 to SmartPAC PRO Wiring, Sensors 17-24 | 36 |
| Table 2-6. DiPro Sensor Interface (DSI) 2 to SmartPAC PRO Wiring, Sensors 25-32 | 37 |
| Table 2-7. ProCamPAC to Cam Output Assembly SMARTPAC PRO Wiring, Cams 1-8..... | 41 |
| Table 2-8. ProCamPAC to Cam Output Assembly SMARTPAC PRO Wiring, Cams 9-16..... | 41 |
| Table 2-9. Connections to Relays | 42 |
| Table 2-10. Aux I/O (TB5) Wiring..... | 44 |
| Table 2-11. SFI Port (1) and Module Port (2) (TB6) Wiring..... | 55 |
| Table 2-12. Special Port (3) and Comm Test Port (4) (TB7) Wiring | 55 |
| Table 2-13. Spare 1 Port (5) and WPC Port (6) (TB8) Wiring | 55 |
| Table 8-1. Communication Errors: SmartPAC PRO Option Identified by Address Number..... | 68 |

HOW TO USE THIS MANUAL

This manual shows you how to install and troubleshoot SmartPAC PRO, including the ProCamPAC and DiProPAC options.

Chapter 2 shows you how to install SmartPAC PRO, including the optional ProCamPAC and DiProPAC modules.

Chapter 8 provides explanations of the messages that display on the SmartPAC PRO front panel when a fault condition occurs or a counter preset is reached, and shows you how to correct SmartPAC PRO faults.

Setup sheets at the end of the manual provide forms on which you can maintain a record of Initialization and Program settings for your SmartPAC PRO.

Wiring diagrams (Figures 1 through 12) following the Setup sheets provide wiring connections for SmartPAC PRO, DiProPAC, ProCamPAC, and the SmartPAC PRO loopback test.

Important Highlighted Information

Important danger, warning, caution and notice information is highlighted throughout the manual as follows:

DANGER

A DANGER symbol indicates an imminently hazardous situation, which, if not avoided, will result in death or serious injury.

WARNING

A WARNING symbol indicates a potentially hazardous situation, which, if not avoided, could result in death or serious injury.

CAUTION

A CAUTION indicates a potentially hazardous situation, which, if not avoided, may result in property damage.

NOTICE

A NOTICE symbol indicates important information that you should remember, including tips to aid you in performance of your job.

WARRANTY

Wintriss Controls warrants that Wintriss electronic controls are free from defects in material and workmanship under normal use and service for a period of one year (two years for Shadow light curtains) from date of shipment. All software products (SFC), electro-mechanical assemblies, and sensors are warranted to be free from defects in material and workmanship under normal use and service for a period of 90 days from date of shipment. Wintriss's obligations under this warranty are limited to repairing or replacing, at its discretion and at its factory or facility, any products which shall, within the applicable period after shipment, be returned to Wintriss Controls freight prepaid and which are, after examination, disclosed to the satisfaction of Wintriss to be defective. This warranty shall not apply to any equipment which has been subjected to improper installation, misuse, misapplication, negligence, accident, or unauthorized modification. The provisions of this warranty do not extend the original warranty of any product which has either been repaired or replaced by Wintriss Controls. No other warranty is expressed or implied. Wintriss accepts no liability for damages, including any anticipated or lost profits, incidental damages, consequential damages, costs, time charges, or other losses incurred in connection with the purchase, installation, repair or operation of our products, or any part thereof.

Please note:

It is solely the user's responsibility to properly install and maintain Wintriss controls and equipment. Wintriss Controls manufactures its products to meet stringent specifications and cannot assume responsibility for consequences arising from their misuse.

Wintriss Controls Group, LLC
100 Discovery Way
Unit 110
Acton, MA 01720
Telephone: (800) 586-TECH (8324)
(978) 268-2700
Fax: (978) 263-2048
Internet: <http://www.wintriss.com>

SmartPAC PRO
INSTALLATION MANUAL
1143200
Wintriss Controls Group, LLC
Copyright 2024

Chapter 2 – Installing SmartPAC PRO

⚠ DANGER

ELECTRIC SHOCK OR HAZARDOUS ENERGY

Disconnect main power before installation.

- Remove all power to the press, press control, and other equipment used with the press.
- Follow your company's lockout procedure per OSHA 1910.147 Control of Hazardous Energy (Lockout/ Tagout).
- Ensure that installation is performed by qualified personnel.
- Complete all installation procedures before connecting to the AC power source.

Failure to comply with these instructions will result in death or serious injury.

NOTICE

UPGRADING TO SMARTPAC PRO FROM SMARTPAC 1 OR 2

To upgrade from legacy products to SmartPAC PRO, see *Instruction Sheet - Upgrading SmartPAC 1 or 2 to SmartPAC PRO* on www.wintrissdocs.com.

⚠ DANGER

PROGRAMMABLE CAM SWITCH NOT FOR SAFETY USE

Use SmartPAC PRO's programmable cam switch to control auxiliary functions only. The SmartPAC PRO programmable cam capability should never be used to provide timing signals for any safety use including clutch/brake control or muting of light curtains.

Failure to comply with these instructions will result in death or serious injury.

NOTICE

OPTIONAL MODULES PROCAMPAC AND DIPROPAC INCLUDED IN MANUAL

When you order your SmartPAC PRO, you may include the DiProPAC die protection and/or ProCamPAC programmable cam switch option. This manual includes instructions for installing and using both modules. Remember that they are options and might not be included in your system. See the following chapters for DiProPAC and ProCamPAC in your SmartPAC PRO user manual:

Chapter 6 – Using DiProPAC Die Protection (Optional)

Chapter 7 – Using ProCamPAC Programmable Cams

If you ordered SmartPAC PRO with other optional modules such as AutoSetPAC load monitor or ProPAC process monitor, refer to the user manual for that option for complete details on its installation and use.

This chapter describes how to install SmartPAC PRO and some of its options. It is organized in the following sections:

| | |
|--------------------------------------------------|----|
| Before You Start | 16 |
| Installation Guidelines | 17 |
| Terminating Cable Shields | 18 |
| Checking the Press | 18 |
| Mounting the SmartPAC PRO Control Enclosure..... | 19 |
| Installing SmartPAC PRO as a Panel Mount..... | 20 |

| | |
|---------------------------------------------------------------------------------------|----|
| Installing SmartPAC PRO in a Pendant | 22 |
| Installing the Resolver | 22 |
| Mounting the Resolver | 24 |
| Wiring the Resolver | 25 |
| Connecting Power Wiring – AC Powered Units | 26 |
| Connecting Power Wiring – 24 VDC Powered Units | 28 |
| Connecting Stop Circuits and Input Check Circuit | 28 |
| Making Wiring Connections | 28 |
| Setting the Input Check Voltage Switch | 29 |
| Adding or Upgrading DiProPAC or ProCamPAC Option | 31 |
| Connecting DiPro Sensor Interface to SmartPAC PRO | 33 |
| Connecting ProCamPAC Programmable Cam Channels | 37 |
| Wiring Setup Mode Circuit | 44 |
| Wiring a Remote Reset Switch (Optional) | 44 |
| Wiring a Sensor-Disabled Output (Optional) | 44 |
| Wiring the ProCamPAC Output with Your Mechanical Top Stop Cam Switch (Optional) | 45 |
| Zeroing the Resolver | 46 |
| Turning on Power to SmartPAC PRO | 46 |
| Verifying Installation of DiProPAC and/or ProCamPAC (Optional) | 47 |
| Moving the Ram to Top Dead Center (TDC) | 48 |
| Setting the Resolver Zero Position | 48 |
| Installing the Position Sensor (Optional) | 49 |
| Final Checkout | 53 |
| Set Up a “Test” Tool | 53 |
| Check and Set Direction of Rotation of Resolver | 53 |
| Check for Position Sensor (If Installed) Error Messages | 53 |
| Check the Top-stop Circuit | 53 |
| Check the Emergency-stop Circuit | 54 |
| Check Cam Channels (ProCamPAC Only) | 54 |
| Test Complete | 54 |
| What Next? | 54 |
| Wiring Tables for Other SmartPAC PRO Connections | 55 |

Before You Start

NOTICE

READ INSTALLATION INSTRUCTIONS BEFORE STARTING INSTALLATION

If you install SmartPAC PRO yourself, read this installation chapter carefully, plan your installation, and figure out what steps you will follow before you start drilling holes, running conduit, or cutting wires.

NOTICE**LEARN TO USE SMARTPAC PRO BEFORE INSTALLING ON A PRESS**

If you have not used SmartPAC PRO before, learn how to initialize and program it before installing it on a press. On the bench, connect your unit to a resolver (Table 2-1, page 26) and to AC power (steps 1-3, page 27) so that you can access all the menus and make settings. See Chapter 1 for instructions on using the touch screen and displays, Chapter 3 for using Initialization mode, Chapter 4 for using Program mode, and Chapter 5 for using Run mode.

Installation Guidelines

Observe the following guidelines when installing SmartPAC PRO:

- Separate high- and low-voltage wires

Never run wires for 120V and for lower voltages (e.g., 24V, 60V) inside the same conduit. Run flexible, liquid-tight conduit for high voltage lines (120V power, input check circuit, stop relay circuits) to the upper right-hand corner of the SmartPAC PRO enclosure. Run one or two low voltage conduits for the resolver and communications control wires into the lower left-hand corner of SmartPAC PRO. If you have top-stop and emergency-stop circuits that are 24V or a voltage other than 120V, you must run them separately from the high-voltage wiring.

Never use the SmartPAC PRO power terminals as a junction point to provide power for external devices. In most cases, the AC power supply wires should be connected directly to the press control cabinet. Do not use the ProCam output enclosure as a junction box for the AC control wires. Provide a separate junction box for this purpose.

Communications wiring should be run separately in its own conduit. Communications wiring will be installed if SmartPAC PRO is connected to the WPC 2000 Wintriss Clutch/ Brake Control, ServoFeed Interface (SFI™), AutoSetPAC, SBR, LETS/SFC, or other equipment.

- Provide NEMA 12 conduit and connections

Because SmartPAC PRO is rated NEMA 12 (i.e., protected against dust and oil), you must use conduit of the same rating and make proper connections to ensure that the enclosure is NEMA-12-protected.

- Properly ground SmartPAC PRO

The ground wire from SmartPAC PRO should be connected to the main ground point of the press control system. This ground point may be in the area where the control transformer is grounded. Finding a good place for a ground is sometimes difficult, but the location should be close to where the press receives its ground.

- Correctly terminate all cable shields

Terminate all cable shields to the studs provided in the enclosure or to a good grounding location (see *Terminating Cable Shields*, page 18).

- Install suppressors across inductive loads

All relays, solenoids, or other inductive loads that are controlled by SmartPAC PRO must be suppressed. Suppressors should be installed across the load and as close to the load as possible.

See Figure 2-15, page 43. Never install a suppressor across relay contacts. If you do, the suppressor may fail shorted, and the equipment controlled by that relay will remain energized. Additional suppressors (part number 2238801) can be obtained from Wintriss Controls.

NOTICE**REMOTE INSTALLATION OF SMARTPAC PRO DISPLAY**

If you install your SmartPAC PRO display separately, in a pendant, for example, see wiring diagrams Figure 7 and Figure 8 for connection details.

Terminating Cable Shields**NOTICE****TERMINATE CABLE SHIELDS CORRECTLY TO MINIMIZE ELECTROMAGNETIC INTERFERENCE (EMI)**

Shielded cables are used with the SmartPAC PRO. For effective shielding, terminate the cable shields as near as possible to the terminal block you are wiring to.

NOTICE**TERMINATE BOTH ENDS OF SHIELD**

Be sure to terminate cable shields at both ends (for example, at SmartPAC PRO and DSI 2).

For each shielded cable, perform the following steps.

1. Strip the cable jacket back about 3 inches.
2. You can terminate the shield braid or drain wire to either a chassis ground stud or under the screw on a PC board standoff. Find one of these as close as possible to the terminal block you are wiring.
3. Connect the shield drain wire or braid to the chassis ground stud or beneath the screw in the PC board standoff.
4. Connect the insulated wires to their designated positions on the terminal block.

Checking the Press

Before starting the installation, remove the die from the press and run the press in all its operating modes: Inch, Single-stroke, and Continuous. Make sure the press has working top- stop and emergency-stop circuits. Verification that the press operates and stops properly is extremely important because SmartPAC PRO will be connected to the press stop circuits. Do not forget to mark on your electrical prints where you connect SmartPAC PRO. Set the press ram to top dead center (TDC).

NOTICE**MOVE RAM TO TDC BEFORE INSTALLING SMARTPAC PRO**

This is an important step because the press must be at top dead center (TDC) when you make final adjustments for the resolver. Be accurate when setting the press to TDC. Set to $0^\circ \pm 2^\circ$. Use a dial indicator on the face of the ram if necessary.

Mounting the SmartPAC PRO Control Enclosure

To mount the SmartPAC PRO enclosure, follow the steps below, referring to Figure 2-1.

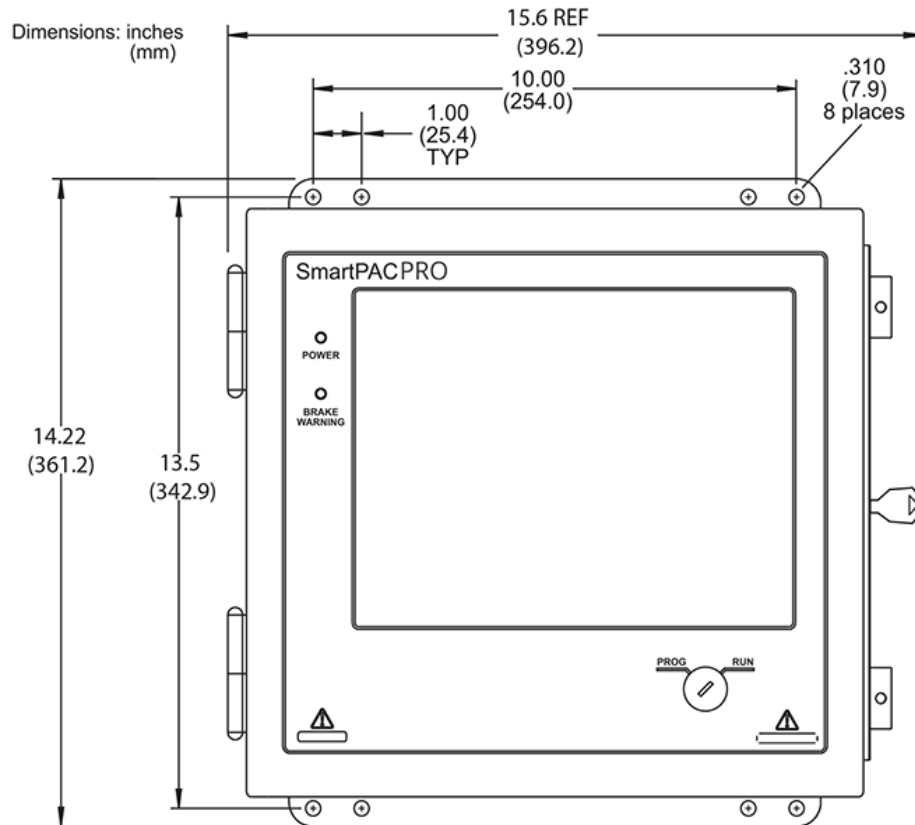

Figure 2-1. SmartPAC PRO Mounting Dimensions

Enclosure mounting – Leave enough room to open the door at least 120° . Leave clearance of approximately 18 inches (46 cm) if you wish to fully open the enclosure's door.

1. Determine a convenient location for the enclosure. Ideally, the enclosure should be mounted where operators and setup personnel can easily see the readouts and reach the display. Make sure that all cables can reach the enclosure. Leave enough room to open the door at least 120° . The enclosure can be mounted on a pedestal, pendant, or the press itself.
2. Drill and tap (if necessary) mounting holes, using a No. 7 drill and 1/4–20 tap, then mount the enclosure, using the enclosed shock mounts. Shock mount studs are 1/4–20.

Installing SmartPAC PRO as a Panel Mount

Follow the steps below to install the panel mount version of the SmartPAC PRO in your enclosure. Be sure to allow at least 6 in. (152 mm) of clearance behind the panel mounting plane to leave enough room for the electronics.

1. Determine a convenient location within your enclosure or console for mounting SmartPAC PRO. Ideally, SmartPAC PRO should be mounted where operators and setup personnel can easily see the readouts and reach the display.
2. Cut out a hole in your enclosure, and drill and tap twelve holes for #10-32 screws, referring to Figure 2-2, page 20, and Figure 2-3, page 21, for mounting and “cutout” dimensions.
3. Prop the panel mount near the cutout location. You can do this by connecting ty wraps from two of the left holes on the panel to the corresponding holes on the enclosure or console, creating hinges.
4. Perform wiring connections as shown in the following sections. Make sure all cables will reach the connectors on the back of the panel mount.
5. When final checkout procedures have been completed (see pages 53 - 54), install the panel mount in your enclosure or console, using twelve #10-32 screws.

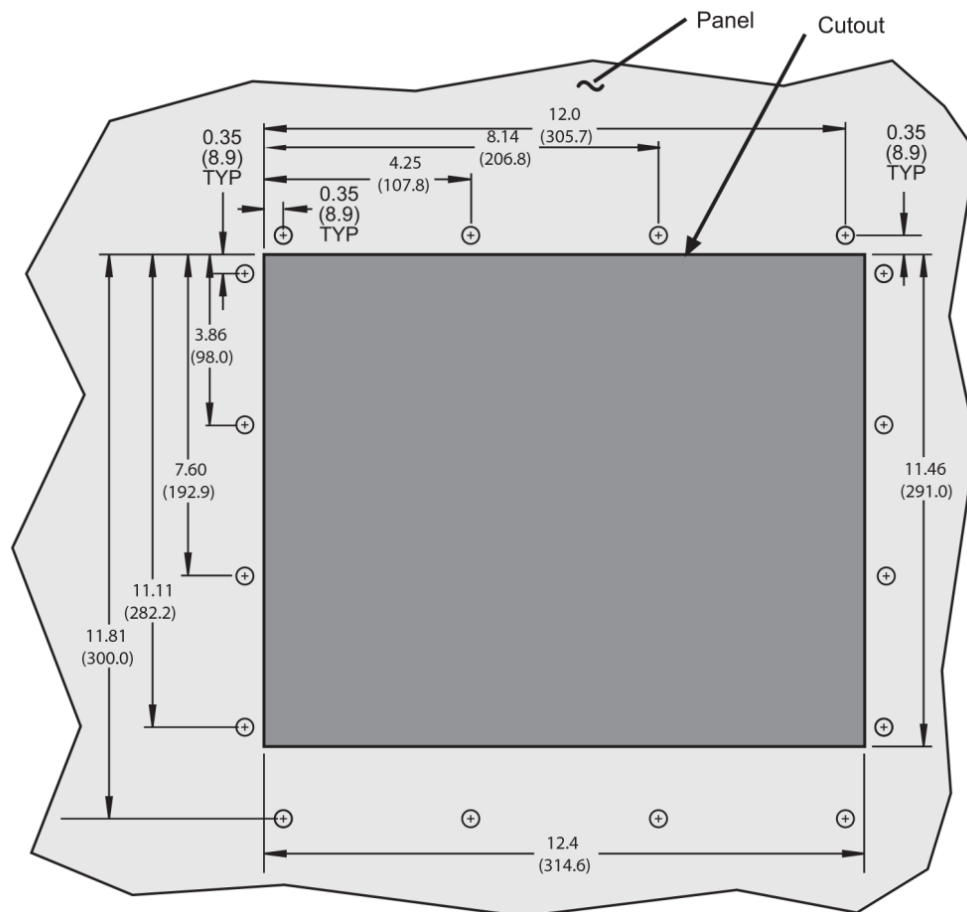

Figure 2-2. SmartPAC PRO Panel Mount Cutout Dimension

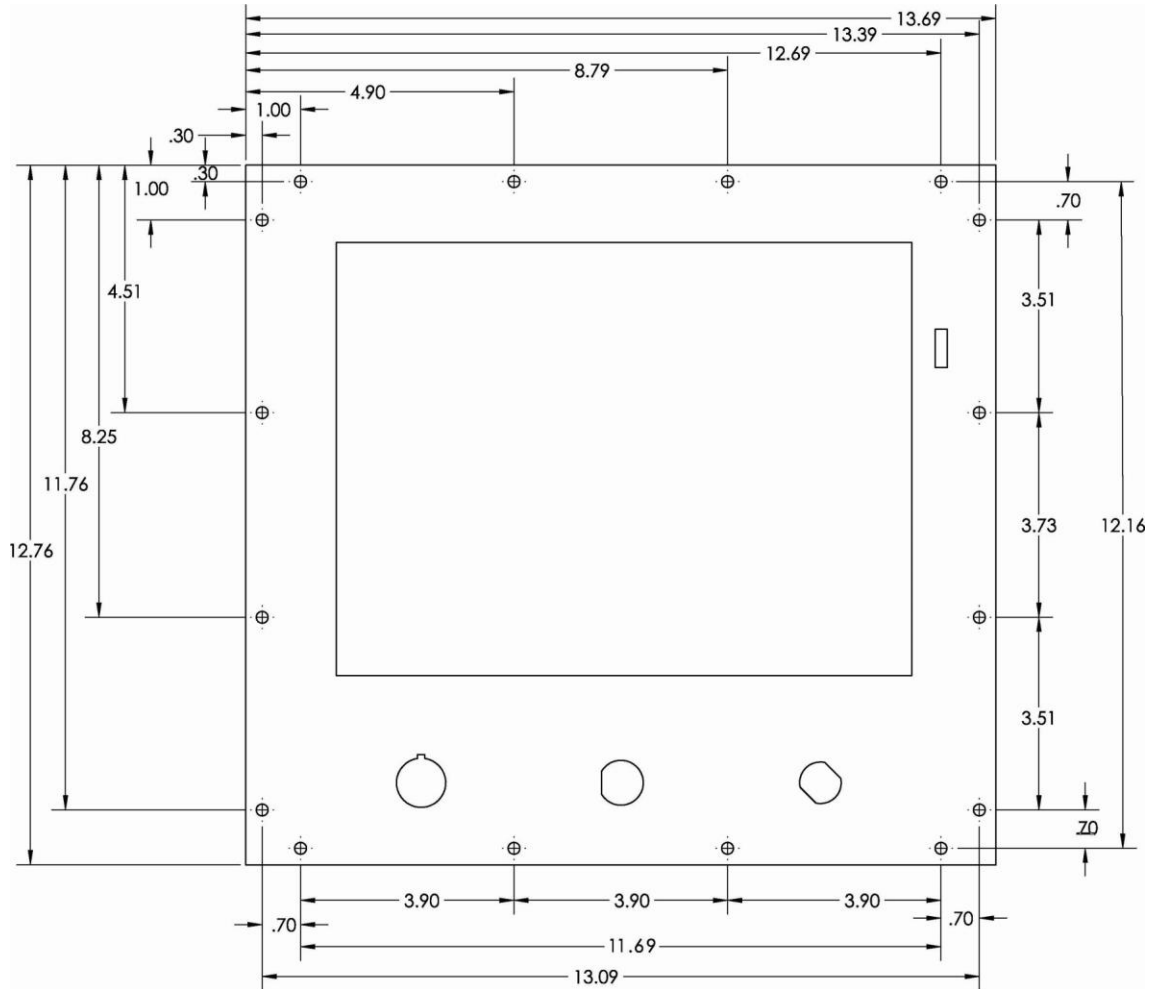

Figure 2-3. SmartPAC PRO Panel Mount Dimensions

Installing SmartPAC PRO in a Pendant

To install the SmartPAC PRO display in a pendant, install the HMI board (display) in the pendant and install the RTS board in the cabinet. Connect with a CAN bus cable, as shown in Figure 2-4. Refer to Figures 10, 11, or 12 at the end of the manual and Table 2-14, page 55.

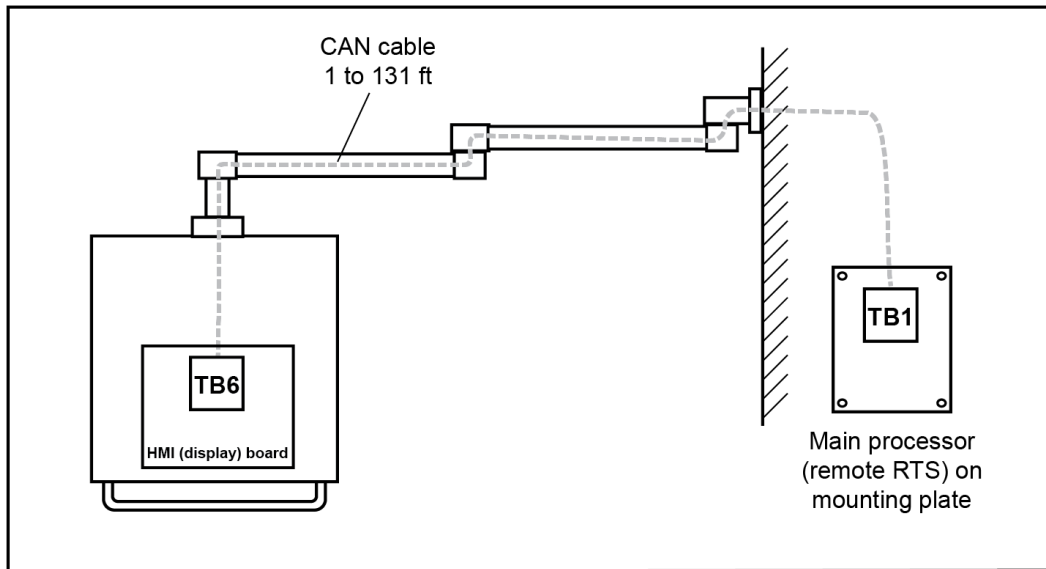

Figure 2-4. Pendant Installation

Installing the Resolver

⚠ DANGER

RESOLVER OUT OF SYNCH WITH CRANKSHAFT

Retain the sprockets on the crankshaft and resolver shaft mechanically so they cannot shift or move out of radial alignment. Be sure that the key on the resolver shaft retains the resolver sprocket. Use a pin or other method to fix the location of the sprocket on the crankshaft.

Failure to comply with these instructions will result in death or serious injury.

The resolver (see Figure 2-5 for dimensions) provides SmartPAC PRO with the exact position of the crankshaft at every angle throughout the stroke (see *Resolver-based Operation* in Chapter 1 of your SmartPAC PRO user manual). To deliver this precision, the resolver must be driven smoothly at a 1:1 ratio with the crankshaft.

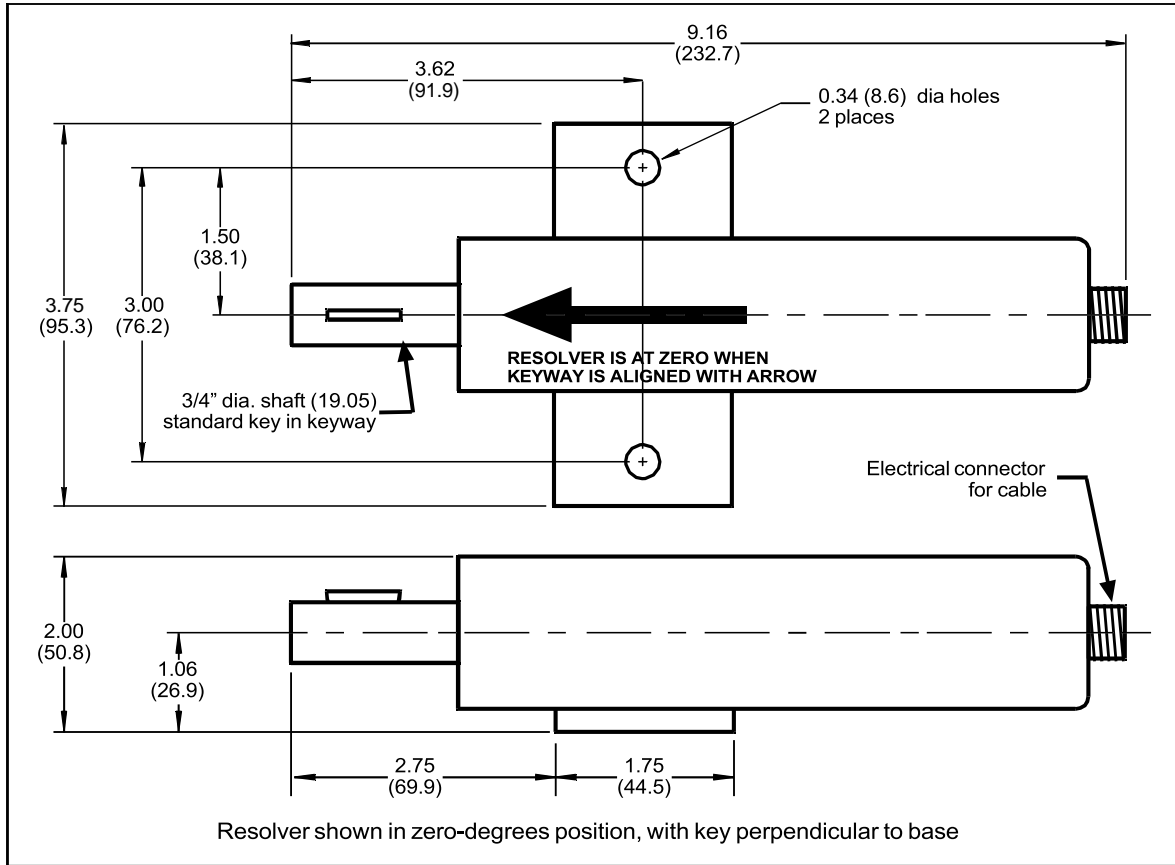

Figure 2-5. Resolver Dimensions

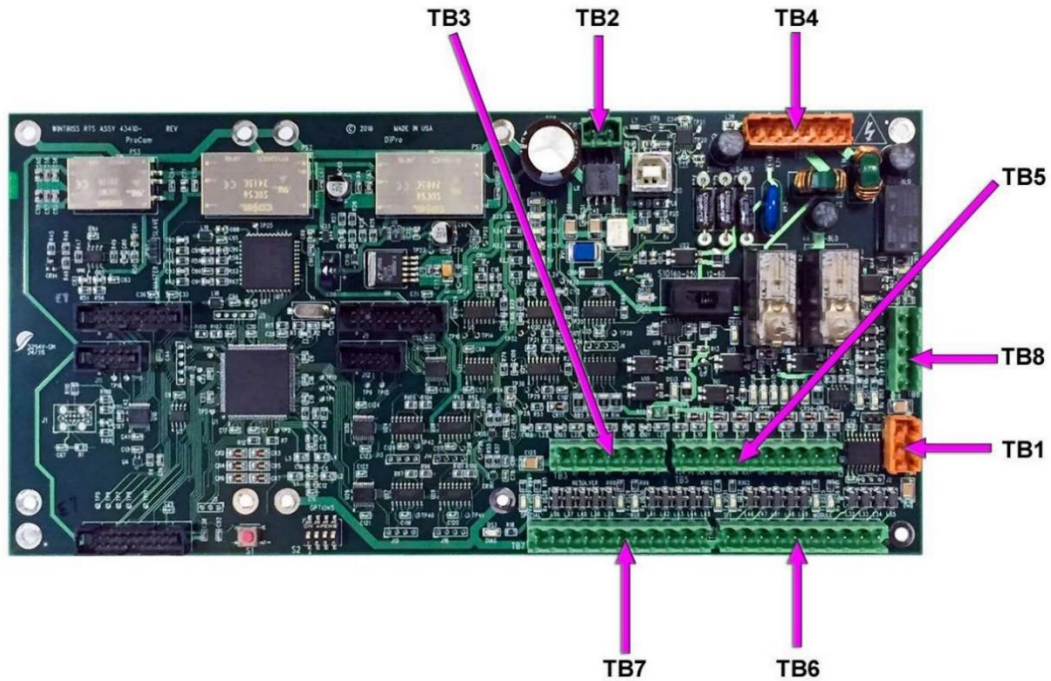

Figure 2-6. Location of Terminal Blocks TB1 through TB8

CAUTION

DAMAGE TO RESOLVER

Be sure that the sprocket or gear driving the resolver chain or timing belt is mounted so that it is centered on the crankshaft. If the gear or sprocket is mounted off-center, the resulting loads on the resolver shaft may cause the resolver to fail.

Failure to comply with these instructions could result in property damage.

Wintriss Controls Group stocks a spring-loaded base (part# 4194300) with a hole pattern that matches the hole pattern on the resolver.

The resolver can turn in a clockwise or counterclockwise direction. You can change the direction of rotation by swapping the black and yellow wires on the resolver connector (see Table 2-1, page 26).

When designing the drive for the resolver, make sure that the drive allows for adjustment of the resolver to its zero position at top dead center. All sprockets must be keyed or pinned. The resolver shaft has a standard key.

Design a method of driving the resolver directly from the crankshaft, using a chain or timing belt (not a V belt) and sprockets. Use either an idler sprocket or spring-loaded resolver base to compensate for slack or stretch.

Observe these additional precautions when designing the resolver drive:

- Do not use a long, sloppy chain. The distance between the center of the resolver shaft and the center of the crankshaft should be no more than 3 feet (1 m).
- Do not use gears, right-angle joints, or shafts with universal joints because these will develop too much backlash or too much play.
- Do not try direct-coupling to the crank because this requires extreme precision. If the resolver is only slightly off-center, the resolver bearing will be subjected to side loads well beyond its rated capacity and will ultimately fail.
- Do not use flexible couplings, which can be inaccurate, or V belts, which may slip and cause inaccuracy.
- Do not use a flexible shaft like a speedometer cable. Because the shaft twists on start-up, the resolver will lag the crank. When the crank stops, the resolver will turn past the true stopping point and snap backward.

Mounting the Resolver

Once you have thought out your design and gathered the parts, mount the resolver as described below. Don't worry about which direction the resolver turns at this point. You will adjust for the direction of rotation later when you wire the resolver.

1. Mount the resolver by bolting it to the press or other platform.
2. Install your drive mechanism.
3. Make sure the press is within $\pm 5^\circ$ of Top Dead Center (TDC).
4. Before attaching the chain or other drive mechanism, rotate the resolver shaft so that the keyway

is aligned with the arrow on the housing. See Figure 2-5.

5. Keeping the resolver's keyway aligned with the arrow (within $\pm 5^\circ$), attach the chain or drive mechanism.

Wiring the Resolver

Wire the resolver as follows, referring to Table 2-1, page 26.

1. Find the resolver cable if it is not connected to the resolver. Plug the end with the connector into the resolver. It only goes one way. Twist the locknut so the connection is tight.
2. Run the resolver cable through 1/2 in. conduit from the resolver to the bottom left knockout of the SmartPAC PRO enclosure.

NOTICE

RUN POSITION SENSOR WIRES WITH RESOLVER WIRES, IF CONVENIENT

If you are installing the position sensor, you can run the position sensor cable through the same conduit as the resolver wires. Since you cannot install the position sensor until the resolver is electronically set to 0° , you will have to leave installation of the position sensor until later (see *Installing the Position Sensor (Optional)*, page 49). Refer to Figure 2-23, page 52, for a typical position sensor mounting location. The position sensor is usually placed near the resolver.

3. Find the resolver connector TB-3 on the SmartPAC PRO board (see Figure 2-6, page 23).
4. Measure and cut the resolver wires so they comfortably reach SMARTPAC PRO. (If you run the position sensor cable through the same conduit, do not cut these wires until the position sensor is installed).
5. Viewing the resolver from the shaft end, determine which direction the shaft will turn – clockwise or counterclockwise – when the press runs.
6. Unplug the L-shaped connector from TB3.

NOTICE

WIRE AND PLUG IN CONNECTOR CORRECTLY

The connector can plug into the receptacle on the PC board in only one direction. Before wiring the connector, mark its left and right ends when it is plugged in to make sure you wire the correct pin numbers.

7. Connect the wires to TB3 as shown in Table 2-1. Make sure you connect the black and yellow wires correctly, based upon the way your resolver will rotate – clockwise or counterclockwise – as you face the resolver shaft.
8. Double-check connections when you are finished wiring.
9. Plug the L-shaped connector firmly into its receptacle on the SmartPAC PRO board. It can plug in only one way.

Table 2-1. Resolver Wiring

| Pin # on TB3 | Resolver Cable Wire Color | |
|--------------|---------------------------|--------------|
| | CW Rotation | CCW Rotation |
| 212 (GND) | No connection | |
| 213 (S1) | Black | Yellow |
| 214 (S2) | Green | |
| 215 (R1) | Red | |
| 216 (S3) | Yellow | Black |
| 217 (R2) | Orange | |
| 218 (S4) | Brown | |

Terminate the cable shield to the ground stud nearest the cable entry.

Connecting Power Wiring – AC Powered Units

WARNING

ELECTRIC SHOCK HAZARD

- Do not connect the AC power source until you are done with all other installation procedures.
- Turn off and disconnect power from the machinery SmartPAC PRO is connected to before making any wiring connections. This includes power to the machine control and motor.

Failure to comply with these instructions could result in death or serious injury.

Run the AC power wires through a “high-voltage” conduit (see *Installation Guidelines*, page 17) along with the wiring for emergency-stop, top-stop, and input check circuits. No. 16 wire (No. 14, if local codes require it) with a minimum 75° C temperature rating is recommended for these circuits. Bring the conduit into the top right knockout of the SmartPAC PRO enclosure. Then, to wire the AC input terminal block, follow these steps:

1. Find the AC terminal block at the top right corner of the back wall of the enclosure (see Figure 2-7).

For a panel mount unit, the terminal block is mounted to the back of the faceplate near the top right corner of the SmartPAC PRO PC board.

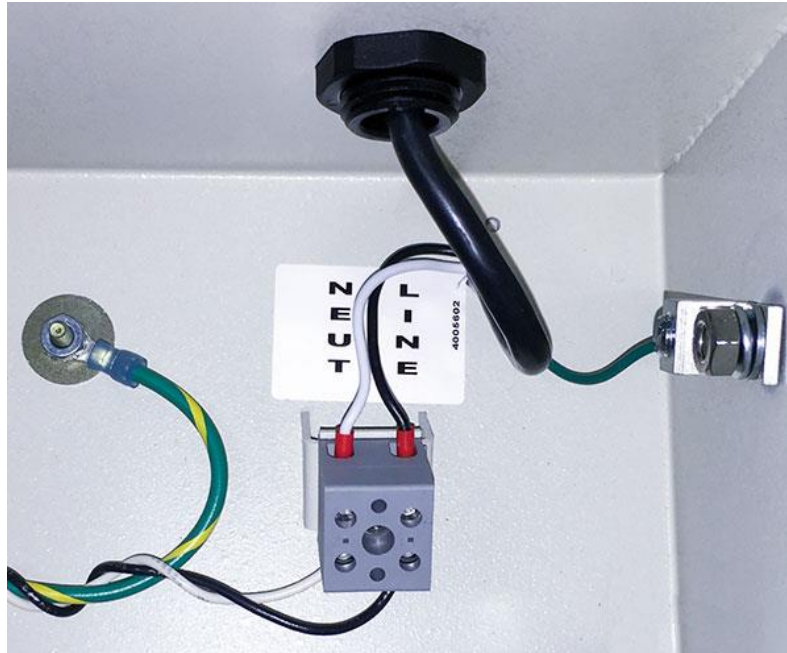

Figure 2-7. Wiring AC to Terminal Block, Inside Enclosure, Top Right

2. Determine how you will bring wiring from your 115 Vac power source (or 230V source, if applicable) to the unit. These wires should be connected directly to the press control transformer at the press control. For 115 Vac, you need three wires: high (black), neutral (white) and ground (green). For 230 Vac, wires are black and red with green or green/ yellow for ground.
3. Connect the AC input wires and ground wire as shown in Figure 2-7 and Figure 4 at the back of the manual. Make your ground connection as follows:
 - **SmartPAC PRO Enclosure:** Connect your ground (green or green/yellow) wire to the set screw terminal on the inside of the enclosure. To connect to the set screw terminal, strip the ground wire about 1/4 in. (6.4 mm) from end, loosen the screw on the terminal, slide the wire in the hole, and tighten the screw to secure the wire in place.
 - **SmartPAC PRO Panel Mount:** Connect the ground wire to the ground stud on the face plate below the AC input terminal block.
4. Connect AC wires to the power source only after all installation procedures have been completed and you are ready to perform final checkout tests (see page 53).

⚠ WARNING

ELECTRIC SHOCK HAZARD

Do not connect the AC power source until you are done with all other installation procedures.

Failure to comply with these instructions could result in death or serious injury.

Connecting Power Wiring – 24 VDC Powered Units

Run a +24V and return wire from a 24VDC, 2A power supply into the conduit on the top of the enclosure on the right side. Connect the +24V wire to TB2 Pin 257, and the return wire to TB2 pin 258.

⚠ WARNING

ELECTRIC SHOCK HAZARD

Do not connect the DC power supply to an AC power source until you are done with all other installation procedures.

Failure to comply with these instructions could result in death or serious injury.

Connecting Stop Circuits and Input Check Circuit

You need four wires to connect SmartPAC PRO to your press control stop circuits, two for the emergency-stop circuit and two for the top-stop circuit. You can wire these circuits at your press control. Refer to your press control manual or other electrical prints.

You need two wires to connect to the input check circuit. These wires are connected in parallel with one of the coils on the Dual Safety Valve that controls the clutch/brake. When the clutch is engaged, 12–250 VAC or VDC (50-60 Hz) must be present across terminals A and B, as shown in Figure 2-8. The connection can be made inside the press control where the circuits to the valve relays are connected. Refer to your press control manual and electrical prints. It does not matter which wire goes to terminal A and which to terminal B.

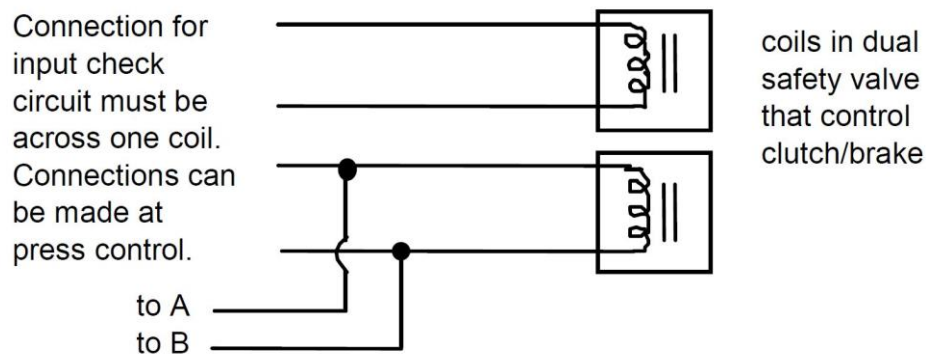

Figure 2-8. Schematic of Input Check Circuit for 10-130 Vac or Vdc

Making Wiring Connections

To make wiring connections from SmartPAC PRO to your press control emergency-stop, top-stop, and input check circuits, do the following:

1. Run the stop circuit and input check circuit wires to SmartPAC PRO through flexible liquid-tight conduit to the enclosure. Because SmartPAC PRO is rated NEMA 12 (protected against dust and oil), you must use conduit of the same rating and make proper connections to ensure that the

enclosure is NEMA-12-protected.

2. Locate connector TB4 on the SmartPAC PRO board (see Figure 2-11, page 32) and unplug it from its socket. Connect the wires for the stop and input check circuits to TB4 pin locations, as shown in Table 2-2 and wiring diagram Figure 4 at the end of the manual.

Table 2-2. Stop and Input Check Circuit Wiring Connections: TB4

| Circuit | SmartPAC PRO TB 4 Pin Locations |
|----------------|--------------------------------------------|
| Input check A | 205 |
| Input check B | 206 |
| E-stop | 207 |
| E-stop | 208 |
| Top-stop | 209 |
| Top-stop | 210 |

3. Plug the connector back into its socket. Double-check connections to make sure that you did not wire the connector backward.
4. Connect top-stop, E-stop, and input check circuit wires at the press control or other box into which you are tying them.

NOTICE

Be sure to number all wires in a way consistent with your press's electrical prints.

5. Make all the necessary conduit connections to ensure NEMA 12 protection.

Setting the Input Check Voltage Switch

To set voltage for the input check circuit, do the following:

1. Find the input check voltage switch, S101, on the SmartPAC PRO board. It is located on the right side of the board just to the left of the E-stop relays.
2. Place S101 in the Left or Right position, depending on the coil voltage of the dual safety valve.

For a coil voltage of 60-250V, place the switch in the Left position (this is the factory setting).
For 12-60V coil voltage, set the switch to the Right setting (Figure 2-9).

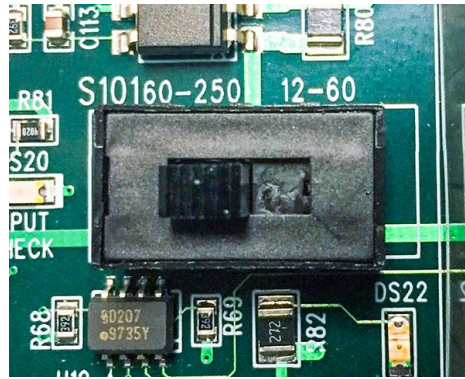

Figure 2-9. Input Check Voltage Switch (S101) in the Factory Default (60-250V) Position



Figure 2-10. Location of Serial Number on SD Card (HMI Board)

NOTICE

HOW THE INPUT CHECK CIRCUIT DETECTS RESOLVER CHAIN BREAKAGE

When the press control energizes the dual safety valve relay to start the press, voltage is induced across the input check circuit. If SmartPAC PRO gets no signal from the resolver within the specified start time limit (resolver not turning), SmartPAC PRO opens the emergency-stop circuit and a “loss of rotation” fault message is displayed on the screen. The fault indicates that the resolver belt or chain is broken or so loose that the resolver shaft cannot move. Other possible reasons for the fault are low air pressure to the clutch or a bad clutch.

Adding or Upgrading DiProPAC or ProCamPAC Option

⚠ WARNING

ELECTRIC SHOCK HAZARD

Turn off and disconnect power from SmartPAC PRO and from the machinery it is connected to before making any wiring connections. This includes power to the machine control and motor. Do not connect the AC power source until you are done with all other installation procedures.

Failure to comply with these instructions could result in death or serious injury.

CAUTION

DAMAGE TO BOARD FROM STATIC DISCHARGE

Ground yourself before touching circuit boards or chips by touching a large metal object such as the press. Static electricity can destroy electronic components.

Failure to comply with these instructions could result in property damage.

NOTICE

INSTALL DIPROPAC AND/OR PROCAMPAC BOARD IN CORRECT LOCATIONS

Install these boards in the locations shown in Figure 2-11, below. If you install a board in the wrong location, SmartPAC PRO will not recognize that the option is installed.

Eight-, 16-, and 32-channel configurations of the same option are interchangeable. When a board is installed in the correct location, SmartPAC PRO recognizes whether it is an 8-, 16-, or 32-channel version of DiProPAC or an 8- or 16-channel version of ProCamPAC.

NOTICE

For information about using the DiProPAC or ProCamPAC options, see in your SmartPAC PRO user manual:

Chapter 6 – *Using DiProPAC Die Protection (Optional)*

Chapter 7 – *Using ProCamPAC Programmable Cams*

The following instructions describe how to add die protection capabilities to a basic SmartPAC PRO. If you ordered either of these options with your new SmartPAC PRO, the boards will have been installed at the factory, and you can skip to the wiring sections for these modules. DiProPAC is available as an 8-sensor, 16-sensor, or 32-sensor board. You can obtain the ProCamPAC board in 8-cam or 16-cam versions.

Wiring instructions for the DiProPAC board are provided below. Wiring for the ProCamPAC board is documented starting on page 37.

To install a new DiProPAC or ProCamPAC board, do the following:

3. On the SmartPAC PRO board, locate the connector in which the new board should be installed (see Figure 2-11).

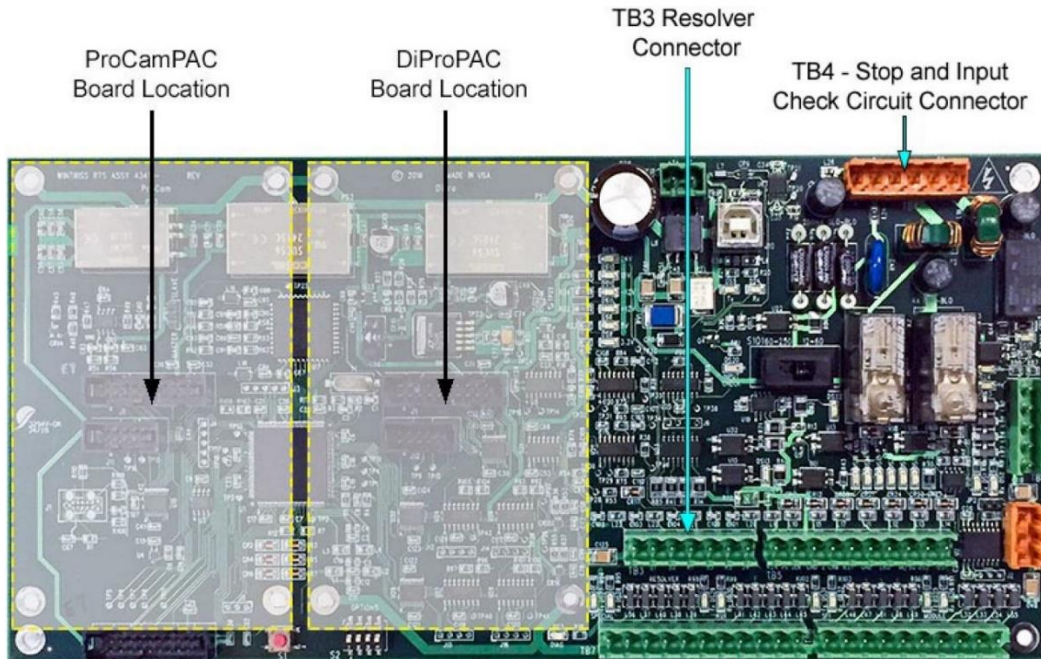

Figure 2-11. SmartPAC PRO Main (RTS) Board Showing Location of Option Module Boards, and TB3 and TB4

CAUTION

DAMAGE TO BOARD FROM STATIC DISCHARGE

Ground yourself before touching circuit boards or chips by touching a large metal object such as the press. Static electricity can destroy electronic components.

Failure to comply with these instructions could result in property damage.

4. Making sure that you are grounded, install the new board by plugging it into the appropriate connector. Connectors are keyed, so you can plug in the boards in only one direction.
5. When the board is properly seated, screw it down to the four standoffs, using the screws that came with the kit.
6. Remove the connector(s) from the board, one connector for an 8-sensor or 8-cam unit, two connectors for a 16-sensor or 16-cam unit, four connectors for a 32-sensor unit. Terminal block assignments for these different boards are as follows. See Figure 2-12.
 - DiProPAC 8: Sensors 1-8 to TB554
 - DiProPAC 16: Sensors 1-8 to TB554, sensors 9-16 to TB554
 - DiProPAC 32: Sensors 1-8 to TB554, sensors 9-16 to TB554, sensors 17-24 to TB555, and sensors 25-32 to TB555
7. Wire the connector(s) to the appropriate component(s). Wire the connector(s) to the DiPro Sensor Interface, following the instructions in *Connecting DiPro Sensor Interface to SmartPAC PRO*, page 33.
8. Plug the connector(s) back into their sockets on the board.

9. Verify that you have installed the board(s) properly by performing the procedure in *Zeroing the Resolver*, page 46. You need to complete this procedure before you can use SmartPAC PRO.

Connecting DiPro Sensor Interface to SmartPAC PRO

NOTICE

For information about using the DiProPAC, see *Chapter 6 – Using DiProPAC Die Protection (Optional)* in your SmartPAC PRO user manual.

To connect your DiPro die protection sensors through the DiPro Sensor Interface (DSI) 2, refer to

- Table 2-3 to wire sensors 1-8
- Table 2-4 to wire sensors 9-16
- Table 2-5 to wire sensors 17-24
- Table 2-6 to wire sensors 25-32.

Refer to wiring diagrams at the end of the manual (Figure 1 for sensors 1-16, Figure 2 for sensors 17-32). Refer to the DSI 2 manual for more information.

Terminate cable shields as close as possible to the terminal blocks, either beneath a screw on a standoff or to a ground stud, as described in *Terminating Cable Shields*, page 18.

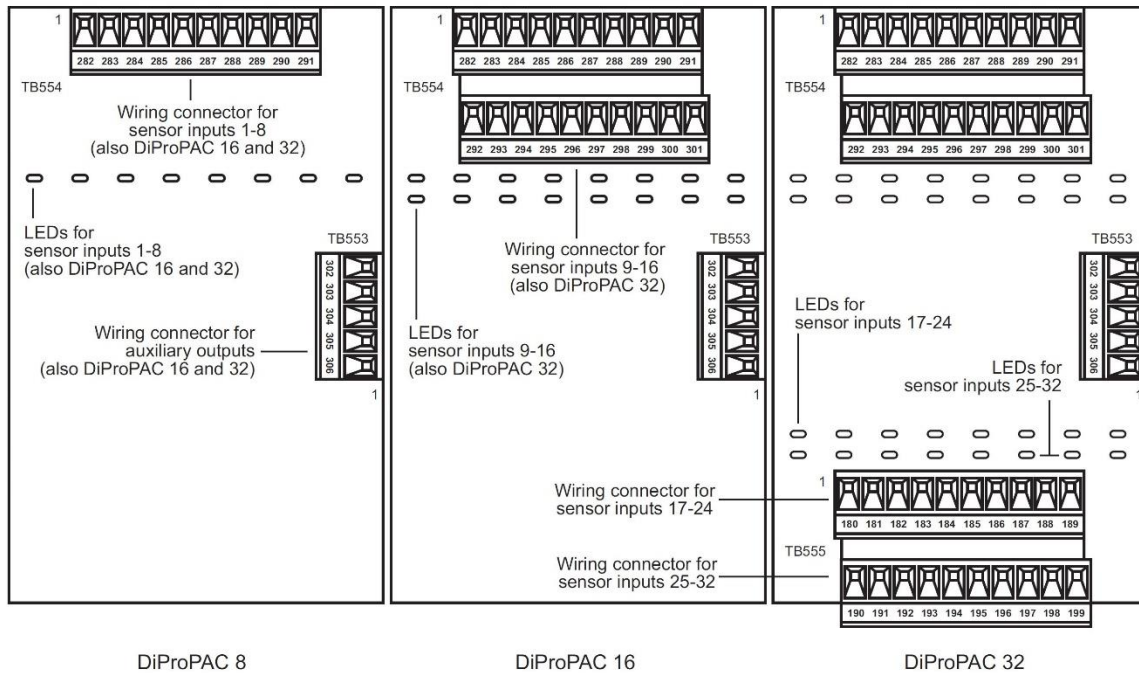

Figure 2-12. DiProPAC Boards (8-, 16-, and 32-Sensor): Location of Components

Table 2-3. DiPro Sensor Interface (DSI) 2 to SmartPAC PRO Wiring, Sensors 1-8

| Wire color* | 1st DSI 2 (TB2) | | DiProPAC (TB554) | |
|-------------|-------------------------------------|-----------------|-------------------------------------|-----------------|
| | Pin # | Pin Designation | Pin # | Pin Designation |
| Brown | 1 | SENSOR 1 | 282 | SENSOR 1 |
| Red | 2 | SENSOR 2 | 283 | SENSOR 2 |
| Orange | 3 | SENSOR 3 | 284 | SENSOR 3 |
| Yellow | 4 | SENSOR 4 | 285 | SENSOR 4 |
| Green | 5 | SENSOR 5 | 286 | SENSOR 5 |
| Blue | 6 | SENSOR 6 | 287 | SENSOR 6 |
| Violet | 7 | SENSOR 7 | 288 | SENSOR 7 |
| Gray | 8 | SENSOR 8 | 289 | SENSOR 8 |
| | | No connection | 290 | Sensor power |
| Black | 9 | GND | 291 | GND |
| | 10 | GND | | No connection |
| | 11 | +5 VDC | | No connection |
| Shield | Terminate drain wire to ground stud | | Terminate drain wire to ground stud | |

* Your colors may be different

Table 2-4. DiPro Sensor Interface (DSI) 2 to SmartPAC PRO Wiring, Sensors 9-16

| Wire color* | 2nd DSI 2 (TB2) | | DiProPAC (TB554) | |
|-------------|-------------------------------------|-----------------|-------------------------------------|-----------------|
| | Pin # | Pin Designation | Pin # | Pin Designation |
| Brown | 1 | SENSOR 1 | 292 | SENSOR 9 |
| Red | 2 | SENSOR 2 | 293 | SENSOR 10 |
| Orange | 3 | SENSOR 3 | 294 | SENSOR 11 |
| Yellow | 4 | SENSOR 4 | 295 | SENSOR 12 |
| Green | 5 | SENSOR 5 | 296 | SENSOR 13 |
| Blue | 6 | SENSOR 6 | 297 | SENSOR 14 |
| Violet | 7 | SENSOR 7 | 298 | SENSOR 15 |
| Gray | 8 | SENSOR 8 | 299 | SENSOR 16 |
| | | No connection | 300 | Sensor power |
| Black | 9 | GND | 301 | GND |
| | 10 | GND | | No connection |
| | 11 | +5 VDC | | No connection |
| Shield | Terminate drain wire to ground stud | | Terminate drain wire to ground stud | |

* Your colors may be different.

Table 2-5. DiPro Sensor Interface (DSI) 2 to SmartPAC PRO Wiring, Sensors 17-24

| Wire color* | 3rd DSI 2 (TB2) | | DiProPAC (TB555) | |
|-------------|-------------------------------------|-----------------|-------------------------------------|-----------------|
| | Pin # | Pin Designation | Pin # | Pin Designation |
| Brown | 1 | SENSOR 1 | 180 | SENSOR 17 |
| Red | 2 | SENSOR 2 | 181 | SENSOR 18 |
| Orange | 3 | SENSOR 3 | 182 | SENSOR 19 |
| Yellow | 4 | SENSOR 4 | 183 | SENSOR 20 |
| Green | 5 | SENSOR 5 | 184 | SENSOR 21 |
| Blue | 6 | SENSOR 6 | 185 | SENSOR 22 |
| Violet | 7 | SENSOR 7 | 186 | SENSOR 23 |
| Gray | 8 | SENSOR 8 | 187 | SENSOR 24 |
| | | No connection | 188 | Sensor power |
| Black | 9 | GND | 189 | GND |
| | 10 | GND | | No connection |
| | 11 | +5 VDC | | No connection |
| Shield | Terminate drain wire to ground stud | | Terminate drain wire to ground stud | |

* Your colors may be different

Table 2-6. DiPro Sensor Interface (DSI) 2 to SmartPAC PRO Wiring, Sensors 25-32

| Wire color* | 4th DSI 2 (TB2) | | DiProPAC (TB555) | |
|-------------|-------------------------------------|-----------------|-------------------------------------|-----------------|
| | Pin # | Pin Designation | Pin # | Pin Designation |
| Brown | 1 | SENSOR 1 | 190 | SENSOR 25 |
| Red | 2 | SENSOR 2 | 191 | SENSOR 26 |
| Orange | 3 | SENSOR 3 | 192 | SENSOR 27 |
| Yellow | 4 | SENSOR 4 | 193 | SENSOR 28 |
| Green | 5 | SENSOR 5 | 194 | SENSOR 29 |
| Blue | 6 | SENSOR 6 | 195 | SENSOR 30 |
| Violet | 7 | SENSOR 7 | 196 | SENSOR 31 |
| Gray | 8 | SENSOR 8 | 197 | SENSOR 32 |
| | | No connection | 198 | Sensor power |
| Black | 9 | GND | 199 | GND |
| | 10 | GND | | No connection |
| | 11 | +5 VDC | | No connection |
| Shield | Terminate drain wire to ground stud | | Terminate drain wire to ground stud | |

* Your colors may be different.

NOTICE

If there are extra wires in the cable, cut them off close to the end of the cable jacket.

Connecting ProCamPAC Programmable Cam Channels

DANGER

PROGRAMMABLE CAM SWITCH NOT FOR SAFETY USE

Use SmartPAC PRO's programmable cam switch to control auxiliary functions only. The SmartPAC PRO programmable cam capability should never be used to provide timing signals for any safety use including clutch/brake control or muting of light curtains.

Failure to comply with these instructions will result in death or serious injury.

CAUTION

BOARD DAMAGE OR SHORT CIRCUIT WHEN MOUNTED WITHOUT ENCLOSURE

- Mount the cam output assembly in a clean area where it will be safe from damage.
- Provide at least 0.5 in. (12.7 mm) clearance between the back of the Cam Outputs board and any metal surface.

Failure to comply with these instructions could result in property damage.

If you purchased the ProCamPAC option with SmartPAC PRO, you receive a separate output

assembly for wiring up to sixteen cam channels to your equipment. The assembly contains the relays that open and close at the angles you set in SmartPAC PRO, turning your equipment on and off. Different types of relays can be used, depending on the voltages of your equipment and any special requirements.

To mount the ProCamPAC Output Assembly and wire it to the ProCamPAC board inside the SmartPAC PRO control, follow the instructions below. These instructions may be used with either the 8- or 16-channel ProCamPAC board. Refer to Table 2-7 and Table 2-8 for wiring connections. A wiring diagram is provided in Figure 3 at the end of the manual.

1. Select a convenient location for running conduit from the ProCamPAC Output Assembly to the equipment that it will control.
2. Mount the output enclosure, using the mounting holes on the flanges as shown in Figure 2-14.
3. Select the relays to be used with each channel. Relays should already be plugged into the Cam Outputs board (see Figure 2-14), each relay labelled with its type (i.e., standard or solid state).

Standard relays can be plugged only into the slots labeled K301 through K305, K307, K309, and K311, which are channels 1-8. Optional solid state relays can be plugged only into slots labeled K306, K308, K310, and K312, which are channels 5-8.

Locate the 12-conductor cable(s) for wiring the ProCamPAC board solid state relay into channel 5 (location K306), you cannot plug a standard relay into location K305. See Figure 2-14.

Example

Say you wish to use three standard relays and one solid state relay. You would install the three standard relays in channels 1 through 3, and the solid state relay in channel 5, skipping the channel 4 output for all wiring and programming.

4. To remove a relay, pull the plastic retention clip away from the relay and pull the relay straight out of its socket. When re-inserting the relay, make sure that the pins line up with the socket holes, then press in firmly.
5. Locate the 12-conductor cable(s) for wiring the ProCamPAC board (see Figure 2-14 for layouts of 8- and 16-channel boards) to terminal block TB301 inside the ProCamPAC Output enclosure. If you are wiring an 8-channel ProCamPAC, one cable is supplied (for channels 1-8). If you are wiring a 16-channel board, two cables are supplied, one for channels 1 through 8, the other for channels 9 through 16.

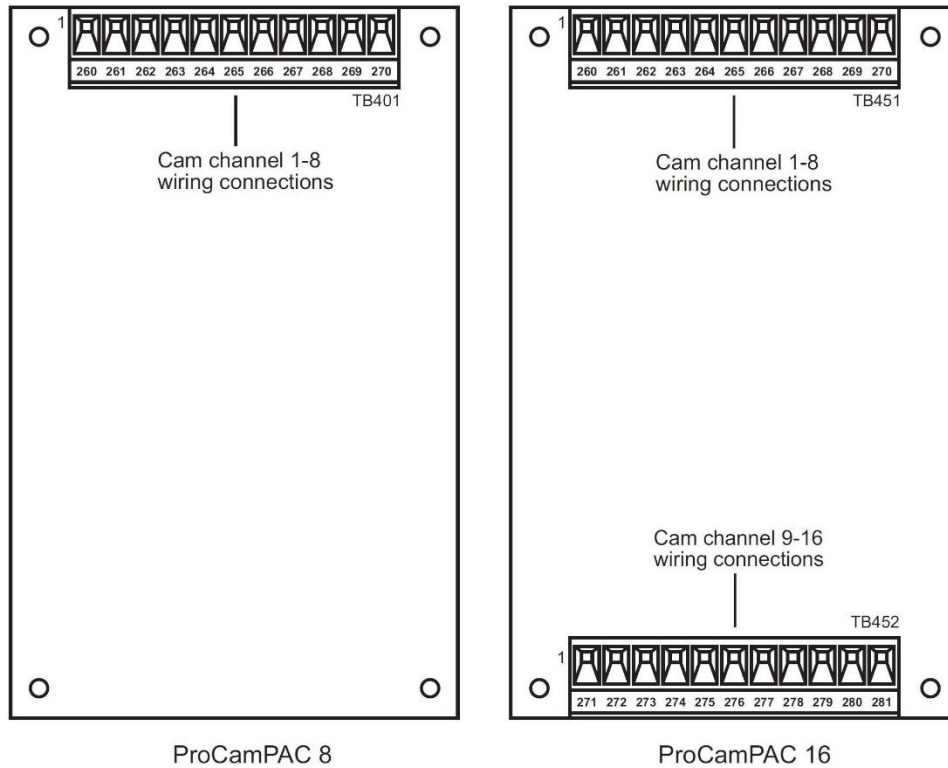

Figure 2-13. ProCamPAC Boards (8- and 16-Channel): Location of Components

6. Remove the appropriate connector(s) from its socket on the ProCamPAC board (TB401 for an 8-channel ProCamPAC, TB451 and TB452 for a 16-channel ProCamPAC). Connect wires from the 12-conductor cable(s) to the pin locations on the appropriate terminal blocks, as shown in Table 2-7 (for the 8-channel option) or Table 2-7 and Table 2-8 (for the 16-channel option). See also wiring diagram Figure 3 at the end of the manual.

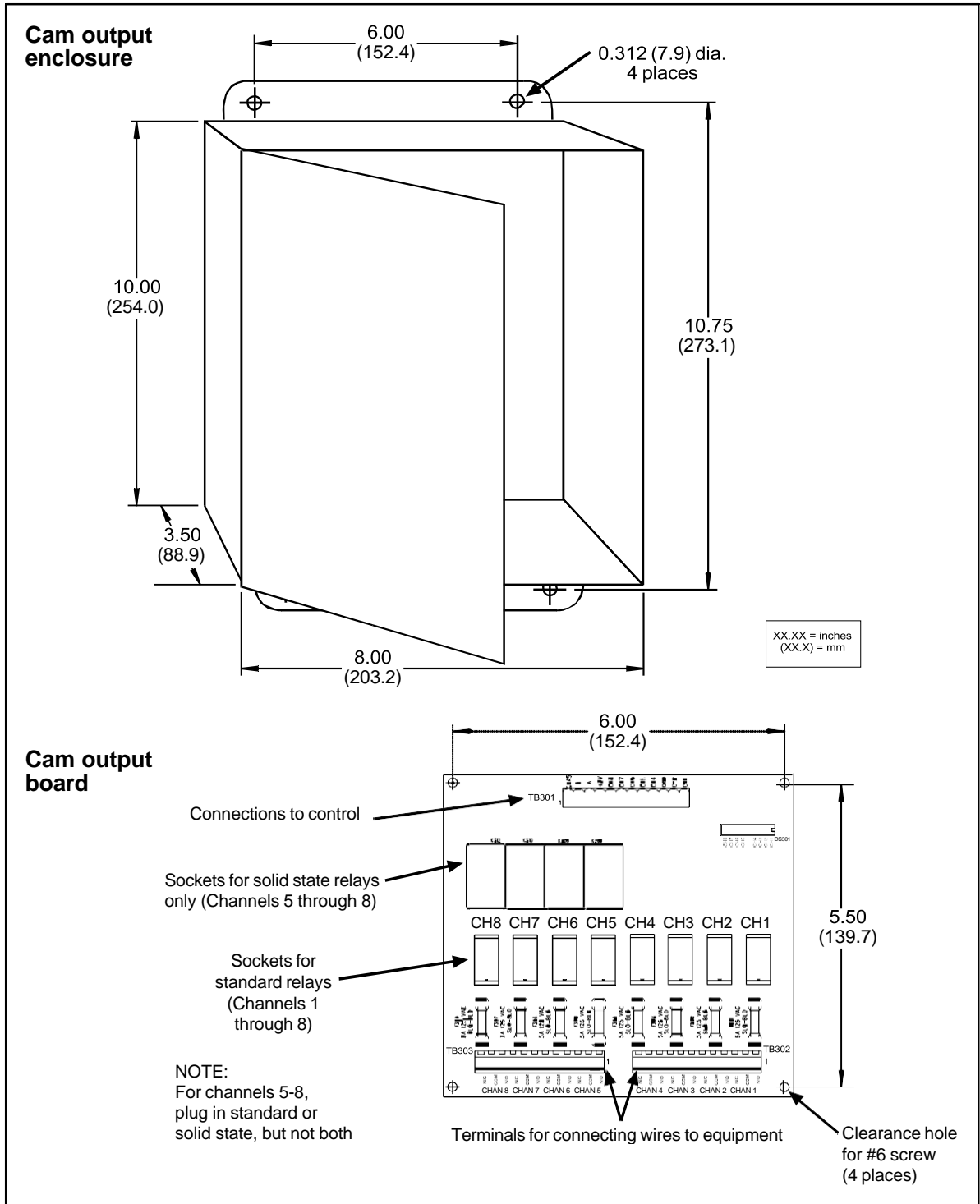

Figure 2-14. ProCamPAC Output Assembly

Table 2-7. ProCamPAC to Cam Output Assembly SMARTPAC PRO Wiring, Cams 1-8

| Wire | 8-cam: ProCamPAC TB401 (cams 1-8) 16-cam: ProCamPAC TB451 (cams 1-8) (Pin #) | 1st Cam Output Board TB301 (Pin #) |
|--------|------------------------------------------------------------------------------------|---------------------------------------|
| | | CHAS (1) |
| White | Relay Pwr (270) | A (3) |
| Black | GND (269) | B (2) |
| Red | +5 (268) | +5 Vdc (4) |
| Tan | Ch 8 (267) | Ch 8 (5) |
| Pink | Ch 7 (266) | Ch 7 (6) |
| Gray | Ch 6 (265) | Ch 6 (7) |
| Blue | Ch 5 (264) | Ch 5 (8) |
| Yellow | Ch 4 (263) | Ch 4 (9) |
| Orange | Ch 3 (262) | Ch 3 (10) |
| Purple | Ch 2 (261) | Ch 2 (11) |
| Brown | Ch 1 (260) | Ch 1 (12) |

Table 2-8. ProCamPAC to Cam Output Assembly SMARTPAC PRO Wiring, Cams 9-16

| Wire | 16-cam: ProCamPAC TB452 (cams 9-16) (Pin #) | 2nd Cam Output Board TB301 (Pin #) |
|--------|------------------------------------------------|---------------------------------------|
| | | CHAS (1) |
| White | Relay Pwr (281) | A (3) |
| Black | GND (280) | B (2) |
| Red | +5 (279) | +5 Vdc (4) |
| Tan | Ch 16 (278) | Ch 8 (5) |
| Pink | Ch 15 (277) | Ch 7 (6) |
| Gray | Ch 14 (276) | Ch 6 (7) |
| Blue | Ch 13 (275) | Ch 5 (8) |
| Yellow | Ch 12 (274) | Ch 4 (9) |
| Orange | Ch 11 (273) | Ch 3 (10) |
| Purple | Ch 10 (272) | Ch 2 (11) |
| Brown | Ch 9 (271) | Ch 1 (12) |

7. Plug the connector(s) back into the socket(s).
8. Run the cable(s) through conduit to TB301 in the ProCamPAC Output enclosure, using the knockouts directly above the connector.
9. Remove the TB301 connector from its socket, and connect wires from the 12-conductor cable(s) as shown in Table 2-7 (for 8-channel ProCamPAC) or Table 2-7 and Table 2-8 (for 16-channel ProCamPAC). A wire from CHAS to a lug on the ProCamPAC Output enclosure should already be connected (unless you bought the board assembly only).

10. Plug the connector(s) back into its socket.
11. To connect the relays to your equipment, use connectors TB302 and TB303.

Specific connections depend on the type of relay you use. For 120 VAC relays, you can connect wires from your equipment to “C” and either the N/O (normally open) or N/C (normally closed) side of the relay

All solid state relays work only when the C and the N/O terminals are connected. Polarity must be correct for DC solid state relays (refer to Table 2-9.)

Table 2-9. Connections to Relays

| Module | How To Connect | Type |
|--------------------------|-----------------------------------------------------------------|-------------|
| Electro-mechanical Relay | One wire to C, one wire to N/O or N/C, polarity does not matter | SPDT |
| DC Solid State | - to C, + to N/O | SPST |
| AC Solid State | One wire to C, one wire to N/O, polarity does not matter | SPST |

WARNING

INCORRECT SUPPRESSOR INSTALLATION MAY CAUSE RELAYS TO REMAIN ENERGIZED

Ensure that suppressors are correctly installed. They must not be installed across the relay contacts inside the ProCamPAC Output enclosure. If a suppressor is installed across the relay contacts and it fails shorted, the equipment controlled by that relay will remain energized.

Failure to comply with these instructions could result in death or serious injury.

12. To reduce electrical noise and to extend the life of the relays, do the following:

AC loads:

Install arc suppressors across each inductive load (motors, coils, etc.) that is connected to a cam relay (see Figure 2-15). Suppressors are supplied with each relay. Install the suppressors across the load or as close to the load as possible. Attach suppressors by connecting leads across existing terminals or junction points.

DC loads:

Install a diode across each DC load, (see Figure 2-16)

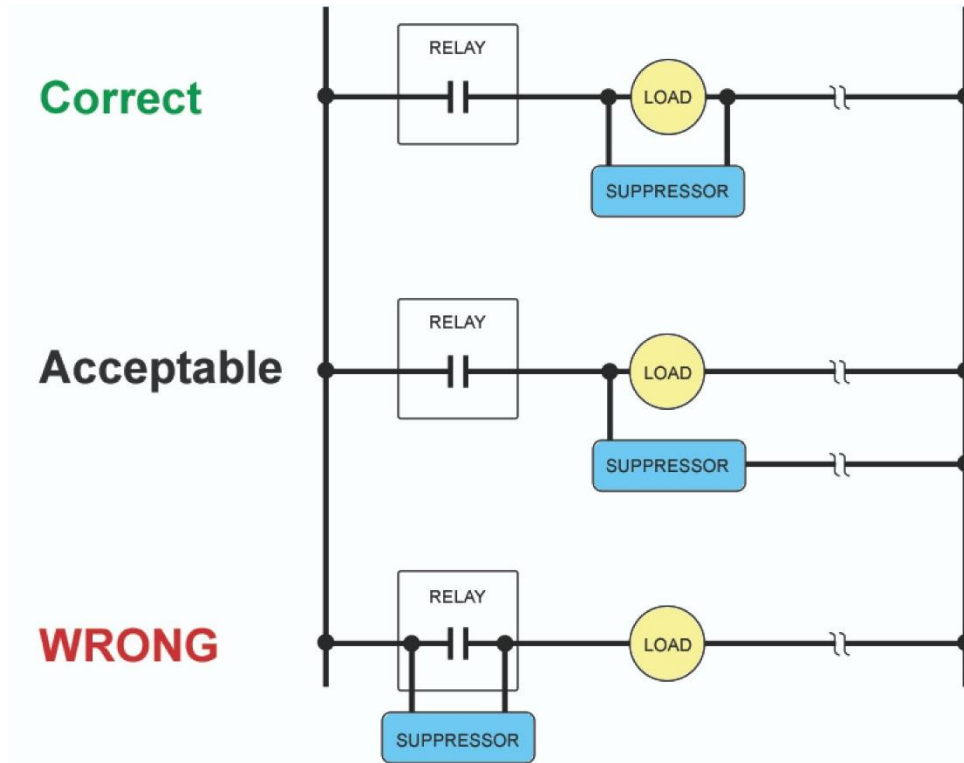

Figure 2-15. Installing Suppressors Across an AC Load

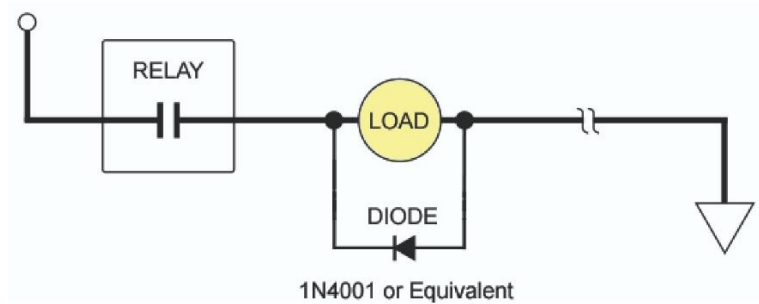

Figure 2-16. Installing a Diode Across a DC Load

Wiring Setup Mode Circuit

SmartPAC PRO Setup mode allows you to disable green sensors and parts/batch counters, using a remote switch. Typically, the Setup mode circuit is enabled when Inch mode is selected on your clutch/brake control. When you inch the press, SmartPAC PRO will not stop the press when a fault condition is detected. The Setup mode terminal can be wired to an extra contact on the Inch position of the Stroke Select keyswitch of your press control, or you can use an external switch to activate the circuit. If you intend to use the Setup mode circuit, plan how you will run your wiring for this connector now so you do not have to disconnect conduit or rerun wires through conduit later.

For Setup mode, you must provide contact closure when a non-Wintriss press control is in Inch mode. Connect a wire from SmartPAC PRO terminal block TB5, terminal #252 (labelled IN/SU) to one side of a normally open switch (see Table 2-10, and Figure 4 at the end of the manual). Connect the other side of the switch to GND (TB5, terminal #247). Refer to your electrical prints or the manual for your press control to plan your wiring.

Table 2-10. Aux I/O (TB5) Wiring

| Pin # | Signal |
|-------|-----------------|
| 245 | +24 V |
| 246 | POSITION SENSOR |
| 247 | GND |
| 248 | ZERO |
| 249 | REMOTE RESET |
| 250 | GND |
| 251 | LOCKOUT |
| 252 | INCH/SETUP |
| 253 | OP STA 2 |
| 254 | OP STA 1 |

Wiring a Remote Reset Switch (Optional)

Like the Setup mode terminal, the Remote Reset terminal can be wired to a normally open switch to activate the circuit. Be sure to plan how you will run your wiring for this connector so that you do not have to disconnect conduit or re-run wires through conduit later. Connect a wire from SmartPAC PRO TB5, terminal #249 (labelled RST) to a normally open switch (see Table 2-10, and wiring diagram Figure 4 at the end of the manual). Connect another wire from the switch to GND (TB5, terminal #250). SmartPAC PRO is reset with a momentary connection to ground.

Wiring a Sensor-Disabled Output (Optional)

You can wire a Sensor-disabled Output such as a warning light to a customer-supplied solid-state relay to warn personnel that the die protection capability, if installed, is disabled.

Connect the positive input wire from your user-supplied 12VDC solid-state relay to terminal #302 (Relay Pwr) on TB553 on the DiProPAC board. Connect the negative input wire from the relay to terminal #306 (Aux 1) on TB553. You cannot use more than 8 mA for your relay.

Wiring the ProCamPAC Output with Your Mechanical Top Stop Cam Switch (Optional)

⚠ DANGER

PROGRAMMABLE CAM SWITCH NOT FOR SAFETY USE

- Use SmartPAC PRO's programmable cam switch to control auxiliary functions only. The SmartPAC PRO programmable cam capability should never be used to provide timing signals for any safety use including clutch/brake control or muting of light curtains.
- Ensure that the clutch/brake control is control reliable on its own. The wiring shown below does not affect or improve the safety of the system. This optional top-stop wiring only aids in adjusting the top stop and in utilizing the auto advance feature to mimic Auto-compensated Top Stop (ACTS).
- Test the system after wiring, as described below, to ensure proper functioning of the Top-stop circuit.

Failure to comply with these instructions could result in death or serious injury.

The diagrams provided in Figure 2-17 show how to wire ProCamPAC and your mechanical cam switch for Top Stop. This optional top-stop wiring only aids in adjusting the top stop and in utilizing the auto advance feature to mimic Auto-compensated Top Stop (ACTS).

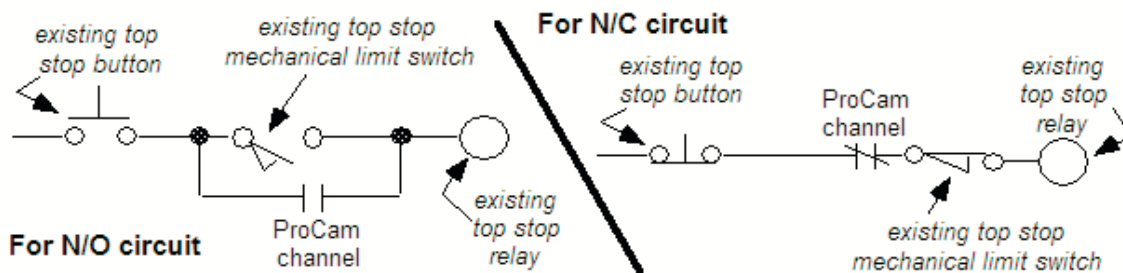

Figure 2-17. Optional Top-Stop Wiring

Check your wiring by performing the appropriate test:

- *For an N/O circuit:* Temporarily program the ProCamPAC channel used for this wiring so that it is “off” (open) all the time (i.e., On = 0°, Off = 0°). Confirm that the press will top- stop.
- *For an N/C circuit:* Temporarily program the ProCamPAC channel used for this wiring so that it is “on” (closed) all the time (i.e., On = 1°, Off = 0°). Confirm that the press will top- stop.

Zeroing the Resolver

NOTICE

PRESS MUST BE AT TDC WHEN ZEROING RESOLVER

Verify that the press is at top dead center (i.e., at $0^\circ \pm 2^\circ$) before you zero the resolver. If the press is not at TDC, your timing settings may be wrong.

You must perform this procedure the first time you power up SmartPAC PRO and whenever you install a new resolver.

If the ram is already at top dead center (TDC), perform the procedure in *Setting the Resolver Zero Position*, page 48. Otherwise, first inch the ram to TDC, following the procedure in *Moving the Ram to Top Dead Center (TDC) procedure*, next.

Turning on Power to SmartPAC PRO

To turn on power to SmartPAC PRO, do the following:

1. Make sure there is no die in the press.
2. Turn the PROG/RUN keyswitch to PROG.
3. Power up the SmartPAC PRO.

The green Power light on the SmartPAC PRO front panel illuminates, the display shows various startup screens, and the Brake Warning LED flashes at approximately two-second intervals while SmartPAC PRO completes its startup routine. This can take up to one minute. Eventually, the Main Program Menu appears, Figure 2-18.

NOTICE

- If an error message displays when SmartPAC PRO starts up, press RESET.
- If the error message continues to appear after your press RESET, find the message in Chapter 8 and follow the instructions for correcting the problem. If you cannot find the error message or cannot fix the problem, contact Wintriss Tech. Support.



Figure 2-18. Main Program Menu

4. If the SmartPAC PRO display remains off, do the following:
 - **If the green Power light on SmartPAC PRO does not illuminate**
Turn off power to SmartPAC PRO, and recheck all power connections. Check that the connectors are correctly seated on both ends of the cables between the SmartPAC PRO board and the display. Power up SmartPAC PRO again. If the display remains off, contact Wintriss Tech. Support.
 - **If the green Power light illuminates, but the display remains off**
Power down SmartPAC PRO, and check that the connectors are correctly seated on both ends of the cables between the SmartPAC PRO board and the display. Power up SmartPAC PRO again. If the display remains off, contact Wintriss Tech. Support.

Verifying Installation of DiProPAC and/or ProCamPAC (Optional)

If you installed DiProPAC and/or ProCamPAC on SmartPAC PRO, you need to verify that the installation was done correctly and that the option is available. Do the following:

1. On the SmartPAC PRO Main Program Menu, select INITIALIZATION MENU; then press INSTALLED OPTIONS. The Installed Options screen, shown in Figure 2-19 displays.

Check to see that DiProPAC and/or ProCamPAC is on the list.

- If it is on the list, go to the next section.
- If DiProPAC is not on the list, go to *Adding or Upgrading DiProPAC or ProCamPAC Option*, page 31, and verify that you performed the installation properly. Check that the option board is plugged into the correct connector. If you still cannot fix the problem, call Wintriss Tech Support.

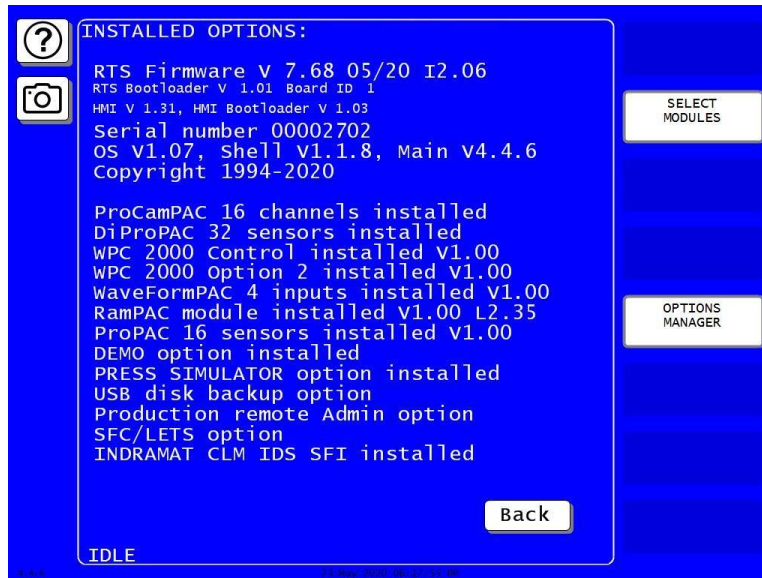

Figure 2-19. Installed Options Screen (yours may list different options)

Moving the Ram to Top Dead Center (TDC)

If the ram is not at TDC, you must first inch the press to $0^\circ \pm 2^\circ$ before you can zero the resolver. Since SmartPAC PRO is now connected to your stop circuits, you must load a tool in order to inch the press.

1. Access Program mode and create a new tool, following the steps in *Creating a New Tool*.in Chapter 4 of your SmartPAC PRO user manual.
2. Enter a counter preset of 10,000 for the tool, following the directions in *COUNTERS* in Chapter 4 of your SmartPAC PRO user manual.
3. Load the tool, following the instructions in *Loading a Tool* in Chapter 4 of your SmartPAC PRO user manual.
4. Turn the PROG/RUN keyswitch to RUN, and inch the press to $0^\circ \pm 2^\circ$.

NOTICE

USE A DIAL INDICATOR TO DETERMINE TDC

Do not rely on the SmartPAC PRO display to indicate when the press has reached TDC. Until the resolver is zeroed, displayed values are inaccurate. Use a dial indicator or some other means to determine 0° .

5. When the press is at TDC, perform the next procedure.

Setting the Resolver Zero Position

To zero the resolver with the press at TDC, perform the following steps:

1. On the SmartPAC PRO Main Initialization Menu select RESOLVER ZERO. The screen shown

in Figure 2-20 displays.

- The value shown in the CURRENT RESOLVER ANGLE field should be as close as possible to 0°, preferably between 355° and 5°, but anywhere between 330° and 30° is acceptable.

If the current resolver angle is outside the range of 330° to 30°, loosen the tension on your drive mechanism and turn the resolver shaft by hand (either direction is acceptable) until the resolver angle is as close to zero as possible. Then tighten the drive mechanism, making sure not to change the resolver angle reading.

- With the Resolver Zero display on the screen, press SET RESOLVER ZERO POSITION. SmartPAC PRO electronically adds or subtracts the offset, and the CURRENT ZERO CORRECTION reading should change to match CURRENT RESOLVER ANGLE.

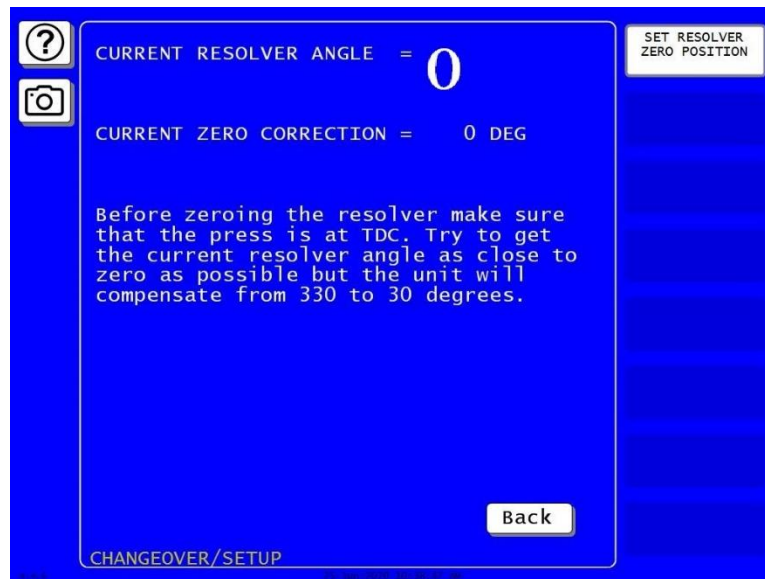

Figure 2-20. “Resolver Zero” Screen

- Press Exit when you are finished. You are returned to the Main Initialization Menu.

Installing the Position Sensor (Optional)

CAUTION

MISALIGNMENT OF RESOLVER AND CRANKSHAFT

If you have installed the position sensor, enable it during initialization and leave it enabled even though it is optional for SmartPAC PRO operation. If you disable the position sensor to clear an error message, misalignment between the resolver and crankshaft will go undetected.

Failure to comply with these instructions could result in property damage.

The position sensor is an optional feature that allows position of the resolver to be checked on every stroke. This feature consists of a magnet, which is usually mounted on the crankshaft, and a magnetic switch, which is mounted on a stationary part of the press past which the magnet passes as the crankshaft turns. The magnetic switch must be mounted so that it senses the magnetic field at the same point on every stroke.

SmartPAC PRO compares the timing of this signal with the angle of the resolver. If the resolver angle changes relative to this signal, SmartPAC PRO knows that the resolver drive has slipped or broken or the resolver itself has failed and issues an Emergency Stop command, simultaneously displaying an error message.

Find a mounting location that allows the magnet to move past the switch once on every stroke and close enough for the switch to sense the presence of the magnet. A gap between switch and magnet of between 1/8 in. and 3/16 in. (about 3–5 mm) is recommended. The position sensor must be mounted so that it is not connected to the resolver shaft or sprocket or any of the drive components leading to the resolver and continue to operate if the resolver or its drive mechanism fails. The position sensor must be installed only after the resolver is zeroed.

To generate an adequate position signal, the magnet should be mounted so the switch senses it for at least 10° to 15° of the stroke. For best results at higher press speeds, mount the magnet on a shaft of 2 in. to 3 in. (about 50–75 mm) diameter. As shown in Figure 2-21, the larger the diameter of the shaft, the shorter the “dwell,” the period during which the switch senses the magnet. To obtain a longer dwell, therefore, mount the magnet on a shaft of smaller diameter.

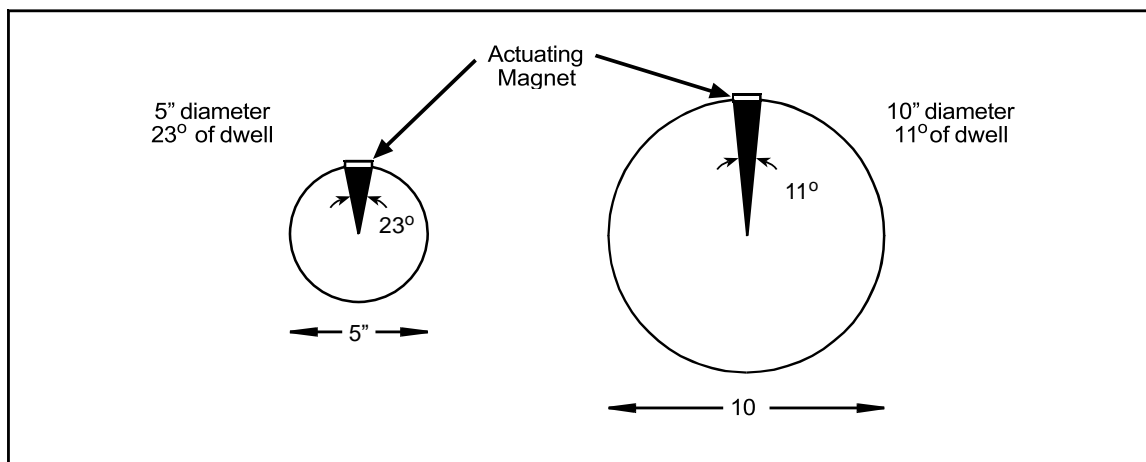

Figure 2-21. Position Sensor Dwell on Different Diameter Shafts

To install the position sensor, do the following:

1. Make sure that the resolver has been zeroed (see *Zeroing the Resolver*, page 46).
2. Turn on power to SmartPAC PRO.
3. Turn the PROG/RUN keyswitch to PROG. The Main Program Menu displays.
4. Select “INITIALIZATION MENU”, then press “POSITION SENSOR” button. The Position Sensor screen, shown in Figure 2-22, displays.
5. Check to make sure that the setting for the POSITION SENSOR MODE item is DISABLED. If it isn’t, press ENTER to toggle to the DISABLED setting.

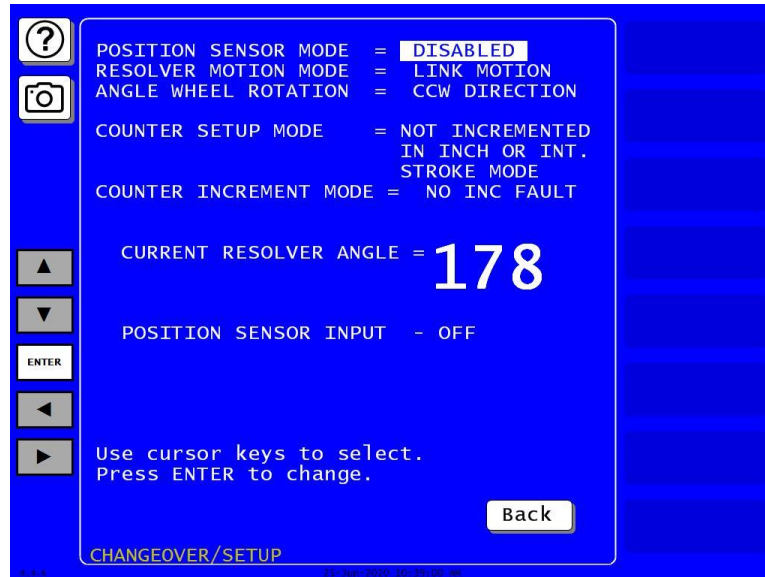

Figure 2-22. Position Sensor Screen

6. Press RESET twice to return to the Main Program Menu.
7. Create a tool, following the steps in *Creating a New Tool* in Chapter 4 of your SmartPAC PRO user manual.
8. Enter a counter preset of 10,000 for the tool, following the directions in *COUNTERS* in Chapter 4 of your SmartPAC PRO user manual.
9. Load the tool, following the instructions in *Loading a Tool* in Chapter 4 of your SmartPAC PRO user manual.
10. Access the Position Sensor screen again (see steps 4 and 5).
11. Check the CURRENT RESOLVER ANGLE setting. If it is not zero (0), inch the press until it reads zero.

NOTICE

The crankshaft angle reading should increase as you inch the press. If it decreases (359°, 358°, 357°, for example), swap the black and yellow wires (terminals 213 and 216) on connector TB3 on the SmartPAC PRO board (see Table 2-1, page 26 and Figure 2-6, page 23).

NOTICE

The press must be at top dead center (0°) before the position sensor can be installed. Make sure that the CURRENT RESOLVER ANGLE setting is 0° before proceeding to the next step.

12. Shut off power to SmartPAC PRO and the press control.
13. Mount the magnetic switch so that the magnet rotates 1:1 with the crankshaft of the press. The ideal location is on the crankshaft itself.
14. Temporarily mount the magnet, plastic side up, so it is centered beneath the magnetic switch as shown in Figure 2-23.

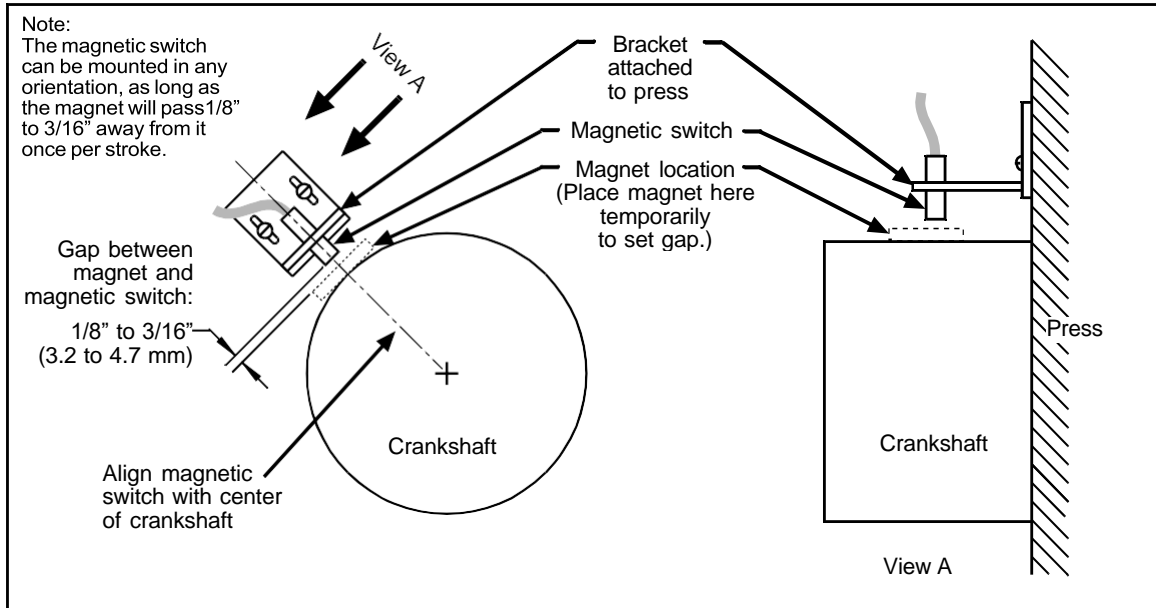

Figure 2-23. Position Sensor Installation

15. Wire the switch to SmartPAC PRO terminal block TB5 (see Table 2-10, page 44 and Figure 4 at the end of the manual). The black wire goes to terminal 247 (GND), the white or clear wire goes to terminal 246, and the red wire goes to terminal 245.
16. Power up SmartPAC PRO and turn the PROG/RUN keyswitch to PROG.
17. Access the Position Sensor screen again (see steps 4 and 5).
18. With the highlight bar on the DISABLED setting for the POSITION SENSOR MODE item, press ENTER to toggle to the ENABLED setting.
19. Making sure that the magnet is centered beneath the magnetic switch, check the reading next to the POSITION SENSOR INPUT item. If the reading is ON, go to the next step. If the reading is OFF, there is a problem. Try the following remedies:
 - Double-check the wiring.
 - Make sure that the ram hasn't moved since you installed the sensor. If it has, move the ram to TDC (i.e., 0°) and re-install the magnet (see step 14).
 - If the ram hasn't moved, check the distance between the magnetic switch and the magnet. Re-adjust if necessary.
 - If a "Position Sensor Incorrect" error message displays after you try running the press (see step 22), the position sensor may not have enough dwell to provide an adequate signal at high speeds. Try mounting the magnet on a smaller shaft (see Figure 2-23).
 - If none of these steps changes the POSITION SENSOR INPUT setting to ON, the magnetic switch may be bad. Try another switch if one is available. Otherwise, call Wintriss Tech. Support for help.
20. Press EXIT and Turn the PROG/RUN keyswitch to RUN.
21. Inch the press through a few strokes to verify that the position sensor works properly and SmartPAC PRO does not produce position sensor fault messages.

- Inch the press while watching the Position Sensor LED, located beneath the Input Check Voltage Switch on the SmartPAC PRO board. Stop the press when the LED comes ON and make a note of the ON angle. Continue to inch the press until the LED goes OFF, and make a note of the OFF angle. The sensor should be ON at 0°, and, preferably, 0° should occur at the midpoint of the ON period.

NOTICE

Do not use a ferrous screw to mount the position sensor. A ferrous screw can cause false signals.

- If the position sensor appears to be working properly, permanently mount the magnet, plastic side up, using a non-ferrous metal screw. A brass screw (6-32) is supplied. Use a No. 36 drill and a 6-32 tap.

Final Checkout

Before using SmartPAC PRO, you need to follow these instructions to ensure that your unit is working properly. Do not proceed to the next step or group of steps until the item you are testing checks out.

Set Up a “Test” Tool

- Create a “Test” tool, following the steps in *Creating a New Tool* in Chapter 4 of your SmartPAC PRO user manual.
- Enter a counter preset of 10,000 for the tool, following the directions in *COUNTERS* in Chapter 4 of your SmartPAC PRO user manual.
- Load the tool, following the instructions in *Loading a Tool* in Chapter 4 of your SmartPAC PRO user manual, then turn the PROG/RUN keyswitch to RUN.

Check and Set Direction of Rotation of Resolver

- Inch the press. Watch the crankshaft angle reading inside the crank angle clock at the lower left of the display. The crankshaft angle should increase as you inch the press. If it decreases (359°, 358°, 357°, for example), swap the black wire and yellow wire (terminals 213 and 216) on connector TB3 on the SmartPAC PRO board (see Table 2-1, page 26).

Check for Position Sensor (If Installed) Error Messages

- If a position sensor is installed and a position sensor fault occurs, refer to step 19 of the procedure in *Installing the Position Sensor (Optional)*, page 49. For other error messages, go to *Chapter 8* and follow the instructions for solving the specific problem. When you have corrected the error, press RESET and run the press again for a few strokes, checking for error messages.
 - If no error messages display, go to step 6.
 - If error messages continue to display, and you cannot correct the fault, call Wintriss Tech. Support.

Check the Top-stop Circuit

- Set the stroke counter preset to a small value (e.g., 10), referring to *COUNTERS* in Chapter 4 of

your SmartPAC PRO user manual; then, run the press in continuous mode until the preset value is reached. Check to make sure that the press top-stops and that a message indicating that the preset was reached is displayed (see Chapter 8 for counter preset messages).

- If the press top-stopped correctly, go to step 7.
- If the press did not top-stop and SmartPAC PRO displayed a message, there is a wiring problem in your top-stop circuit. Recheck all wiring and trace the cause of the problem.

Check the Emergency-stop Circuit

7. Perform the 90° stop-time test to verify that the emergency-stop circuit is working, referring to the procedure *Performing the 90° Stop-time Test* in Chapter 5 of your SmartPAC PRO user manual.
 - If the press stops correctly, go to step 8.
 - If the press does not stop, there is a wiring problem in your emergency-stop circuit. Recheck all wiring and trace the cause of the problem.

Check Cam Channels (ProCamPAC Only)

8. Create some test settings for your cam channels in Program mode (see *Run Mode: CAM SWITCH (ProCamPAC)* in Chapter 7 of your SmartPAC PRO user manual), load the tool settings, and switch to Run mode to run the press. Ensure that the equipment (feed, blow off, lube, etc.) controlled by each channel is operating appropriately according to the settings you made.

Test Complete

9. If you get to this step, SmartPAC PRO is working correctly. Clear any error messages by pressing RESET, then delete the test tool. You can now create a tool in SmartPAC PRO, program settings for it, load it, and begin to make parts using your new SmartPAC PRO.

What Next?

To program and use your SmartPAC PRO, follow the instructions in the remaining chapters of this manual. Refer to Chapter 3 – *Initialization* in your SmartPAC PRO user manual to make Initialization settings for your SmartPAC PRO.

Wiring Tables for Other SmartPAC PRO Connections

Table 2-11. SFI Port (1) and
Module Port (2) (TB6) Wiring

| Pin # | Signal | Port |
|-------|--------|--------------------|
| 235 | +RXD1 | SFI PORT (1) |
| 236 | -RXD1 | |
| 237 | TXD1 | |
| 238 | +TXD1 | |
| 239 | -TXD1 | |
| 240 | GND | |
| 241 | +RXD2 | MODULE PORT (2) |
| 242 | -RXD2 | |
| 243 | +TXD2 | |
| 244 | -TXD2 | |

Table 2-12. Special Port (3) and
Comm Test Port (4) (TB7) Wiring

| Pin # | Signal | Port |
|-------|--------|---------------------|
| 224 | +RXD3 | SPECIAL PORT (3) |
| 225 | -RXD3 | |
| 226 | TXD3 | |
| 227 | +TXD3 | |
| 228 | -TXD3 | |
| 229 | GND | |
| 230 | +RXD4 | PORT (4) |
| 231 | -RXD4 | |
| 232 | TXD4 | |
| 233 | +TXD4 | |
| 234 | -TXD4 | |

Table 2-13. Spare 1 Port (5) and
WPC Port (6) (TB8) Wiring

| Pin # | Signal | Port |
|-------|--------|---------------------|
| 330 | -TXD6 | WPC PORT (6) |
| 329 | +TXD6 | |
| 328 | -RXD6 | |
| 327 | +RXD6 | |
| 326 | GND | |
| 325 | -TXD5 | |
| 324 | +TXD5 | SPARE 1 PORT (5) |
| 323 | TXD5 | |
| 322 | -RXD5 | |
| 321 | +RXD5 | |

Table 2-14. CAN Bus Wiring

| HMI Board TB6 | | RTS Board TB1 (CAN BUS) | |
|------------------|---------------|----------------------------|--------|
| Pin# | Signal | Pin# | Signal |
| 1 | +CN | 1 | CN- |
| 2 | no connection | 2 | Shield |
| 3 | -CN | 3 | CN+ |

Chapter 8 – SmartPAC PRO Fault Messages

NOTICE

IMPORTANT INFORMATION TO PROVIDE WHEN CALLING WINTRISS TECH. SUPPORT

When you contact Wintriss Controls for technical assistance, be ready to provide the following information to expedite a resolution to the problem: product name (e.g., SmartPAC PRO); installed options (e.g., DiProPAC, ProCamPAC, etc.); and firmware version number (e.g., Vs. 2.00). You can determine the last two items by accessing the Installed Options screen in Initialization mode (see *INSTALLED OPTIONS* in Chapter 3 of your SmartPAC PRO user manual)

This chapter documents the fault messages that display on the SmartPAC PRO screen or in the Error/Event Log, providing a brief explanation of each message and a remedy for correcting the problem.

Responding to the Brake Warning LED

When the Stopping Time of the press increases to within 10 mS of the Stop-time Limit set in Initialization (see SET BRAKE MONITOR in Chapter 3 of your SmartPAC PRO user manual), the amber Brake Warning LED on the SmartPAC PRO front panel will flash. Illumination of this LED often means that the brake is worn and/or defective. To respond, do the following:

1. Contact your maintenance crew immediately and have them investigate the condition of the brake.
2. If the brake checks out, your Stop-time Limit is too tight, not allowing for normal wear. Set a new Stop-time Limit, referring to *Setting Stop Time and Start Time Limits* in Chapter 3 of your SmartPAC PRO user manual.
3. Power down the SmartPAC PRO, then power it back up to turn off the Brake Warning LED.

When the Stopping Time exceeds the Stop-time Limit, the “Stop time exceeded” message displays (see page 62).

Responding to Fault Messages

When an error occurs, a red message window like the one shown in Figure 8-1 is displayed. The error windows indicate the exact nature of the error and provide a brief explanation.



Figure 8-1. Error Code Message

If the press stops because one of the counter presets has been reached, a yellow message window like the one shown in Figure 8-2 displays.



Figure 8-2. Counter Preset Message

When an error message displays, correct the malfunction or other problem, consulting the Problem and Remedy descriptions for the appropriate error message in the sections that follow. When the problem has been corrected, press Exit (or Remote Reset Button, if installed) to clear the message. If the problem has been solved, you will be able to run the press. Otherwise, you will get the fault message again.

If the problem persists, contact Wintriss Tech. Support. Do not attempt to run the press before correcting the problem.

In the following sections, messages are grouped in four categories:

- Messages that display when a counter preset is reached
- Messages that display for equipment or brake monitor problems
- Messages that display for programming problems
- Messages that display when a sensor signals a fault

Counter Preset Reached Messages

“S03 Good parts counter preset reached TS”

Explanation: The value set for the parts counter has been reached. The press should stop at top dead center.

Remedy: Press RESET to clear the message. The Good Parts Count will be automatically reset to 0. If your part run is complete, you need to change tooling, material, etc. before you re-start the press.

“S06 Strokes counter preset reached TS”

Explanation: The value set for the strokes counter has been reached. The count will be automatically reset to 0. The press should stop at top dead center.

Remedy: Press RESET to clear the message. If your part run is complete, you need to change tooling, material, etc. before you re-start the press.

“S0x Batch # counter preset reached TS”

Explanation: The value set for one of the three batch counters when the output type is set to TOP STOP has been reached. The press should stop at top dead center. See *Setting Batch Counter Output and Increment Modes* in Chapter 5.

Batch 1 – S04

Batch 2 – S07

Batch 3 – S08

Remedy: Press OK to clear the message.

NOTICE

When this message appears, the corresponding batch count is automatically reset to 0.

Messages for Equipment or Brake Monitor Problems

The following messages cover resolver, input circuit, and position sensor faults, problems with the way the press is running, brake monitor faults, and internal problems with SmartPAC PRO.

“S11 Loss of rotation ES”

Explanation: The resolver did not start rotating within the start time limit set in Initialization (see *SET BRAKE MONITOR (Optional with WPC 2000 Integration)* in Chapter 3 of your SmartPAC PRO user manual) or stopped rotating while the press was running.

SmartPAC PRO knows when the Dual Safety Valve (DSV) is energized. If it sees that the DSV is energized but the resolver is not turning, this message appears.

One possible cause is that the resolver’s drive belt is loose or broken. Another is that you may have low air pressure to the clutch or a bad clutch. An internal SmartPAC PRO problem could also have occurred, or the resolver could be defective.

Remedy: Check the resolver, the resolver drive, and the clutch. Repair if necessary.

If these solutions do not work, an internal problem may have occurred. Call Wintriss Tech. Support.

“Angle resolver failure”

Explanation: The wiring input check circuit failure in the resolver circuit to SmartPAC PRO may be loose or bad, or the resolver may have failed. Another possible cause is that the press may be going faster than 800 SPM (or 1600 SPM, depending on the speed setting in SmartPAC PRO).

Remedy: Check the resolver wiring and connections for shorts, breaks, or loose connections; see *Wiring the Resolver*, page 25.

- If SmartPAC PRO’s rated press speed has been exceeded, reduce the speed.
- If the speed has not been exceeded, make sure that the speed has been set correctly.
- If you purchased the high-speed option (up to 1600 SPM), make sure it is enabled on the Options Manager screen. see *OPTIONS MANAGER* in Chapter 3 of your SmartPAC PRO user manual.
- If these remedies do not correct the problem, the resolver may need to be replaced. Contact the Wintriss Tech. Support for assistance.

NOTICE

To clear this fault, you must cycle power to SmartPAC PRO.

“S12 Input check circuit failure”

Explanation: The resolver turned five times, indicating that the press was running, but SmartPAC PRO received no signal from the input check circuit. The input check circuit may not have been connected or wired properly. If this message occurs when the press stops, the brake may be worn.

Remedy: Check the wiring of the input check circuit and rewire, if necessary, following the instructions in *Connecting Stop Circuits and Input Check Circuit*, page 28. If the input check circuit is not the problem, check your brake for wear.

“S10 Position sensor incorrect ES”

Explanation: The position sensor was not closed at 0° or was not open at 180°.

The position sensor, which cross-checks the position of the resolver to ensure that it is working correctly, should be installed so that it closes at zero resolver degrees. If it does not close at 0° or is not open by 180°, the press stops and you see this message.

The resolver drive may have slipped or be broken, or the resolver or position sensor may be defective or not installed properly. Another possibility is that the position sensor may not have enough dwell to close at high speeds. The larger the diameter of the object on which the magnet is mounted, the shorter the dwell (see Figure 2-23, page 52). Also, a position sensor may be enabled in

Initialization without a position sensor being installed.

Remedy: Check the wiring and installation of the resolver and position sensor (see *Installing the Resolver*, page 22, and *Installing the Position Sensor (Optional)*, page 49). If shaft diameter is the problem, mount the magnet on a smaller shaft. If a position sensor is not installed, check to make sure that the POSITION SENSOR setting in Initialization is DISABLED (see *POSITION SENSOR MODE* in Chapter 3 of your SmartPAC PRO user manual).

If none of the above procedures prevents this message from displaying, the sensor may be bad. Try another sensor if available. Otherwise, call the factory for help. Do not run the press until the problem is solved.

NOTICE

- If a position sensor is being used on your press, do not disable it in Initialization mode to clear the error message. Otherwise, misalignment between the resolver and crankshaft will not be detected.
- If you do not have a position sensor, be sure to disable the position sensor in Initialization mode and make no connections to pin #246 on TB5.

E-Stop errors

Explanation: If the word “ESTOP” appears in a message, one or both of the emergency stop relay circuits are not working satisfactorily and may be defective.

Remedy: Check both stop relay circuits. To reset SmartPAC PRO, turn the unit off, then on again. (You cannot use RESET to reset this error.) If the error recurs, contact Wintriss Tech. Support.

“Inboard ram test failure”

Explanation: Something is wrong with the SmartPAC PRO main processor board. The board may need to be serviced or replaced.

Remedy: Try turning the power off, then on again. (You cannot use RESET to reset this error.) If the message continues to appear, contact Wintriss Tech. Support for assistance or replacement of the board.

“Resolver signals incorrect” or “Resolver drive signal incorrect”

Explanation: There is a problem with the resolver assembly.

Remedy: Check to make sure that the Master/Slave jumper, JP101, on the SmartPAC PRO board is set to the following position (see Figure 8-3). JP101 is located underneath the ProCamPAC board if one is installed.

- MASTER for a SmartPAC PRO *without* WPC Clutch/Brake control integration

- SLAVE for a SmartPAC PRO with WPC Clutch/Brake control integration

Check the resolver and wiring. Make sure that the terminals are tightened on bare wire and not on insulation (see *Installing the Resolver*, page 22). If necessary, contact Wintriss Tech. Support for assistance or replacement of the resolver.

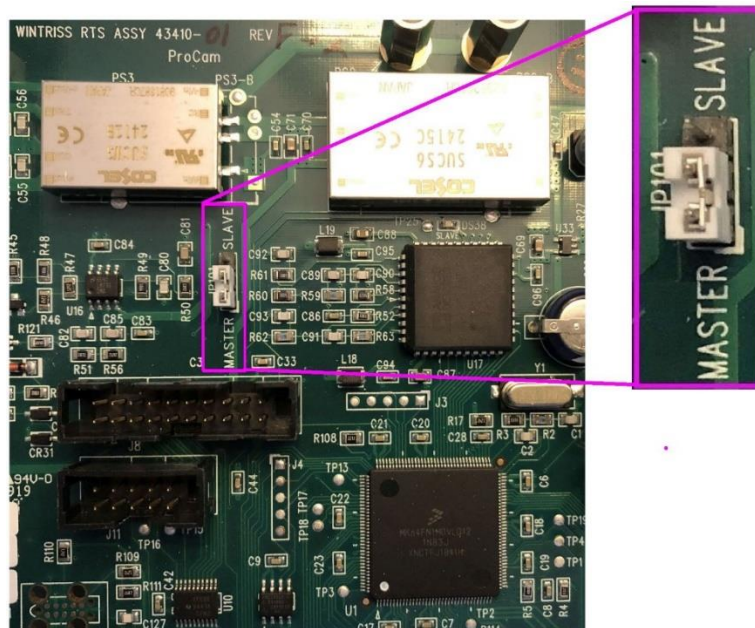

Figure 8-3. Location of JP101

“S13 Stop time exceeded”

Explanation: The stopping time of the press has exceeded the limit set in SmartPAC PRO Initialization. You should have been pre-warned of this condition by the brake warning LED, which flashes whenever the stopping time is within 10 milliseconds of the stop time limit.

This message displays when the stop time limit is not sufficient to allow for normal brake wear, or the brake is excessively worn and needs servicing. If the brake is worn, a dangerous safety problem may exist and should be corrected immediately.

Remedy: Inspect the brake for excessive wear. Perform several 90° stop-time test runs to get an actual reading for your press’s stop time. Compare these results with the results you got the last time you performed the test. Decide if the current stop time limit is realistic or needs to be changed slightly. See *Calculating the Stop Time Limit (Optional with WPC 2000 Integration)* in Chapter 3 of your SmartPAC PRO user manual to calculate the correct stop time limit. See *Performing the 90° Stop-time Test* in Chapter 5 of your SmartPAC PRO user manual to perform the 90° stop-time test. If you change the limit, you may have to relocate your light curtains and/or two-hand controls. Refer to the clutch/brake user manual for details.

If the brake is worn, you should have your maintenance personnel service the brake immediately.

Messages for Programming Problems

These messages indicate that there is a problem with the tool, the tool is not properly loaded, or there is an internal problem with SmartPAC PRO.

“No tool number has been loaded”

Explanation: You are attempting to access Run mode without a tool being loaded. A tool must be loaded before you can enter Run mode.

Remedy: Turn the PROG/RUN keyswitch to PROG to access Program mode, then load the appropriate tool, and turn the PROG/RUN keyswitch back to RUN.

“S09 Tool number table checksum error ES”

Explanation: The programming for the loaded tool has become corrupted. This error can occur when SmartPAC PRO has been turned off while you are in the middle of programming a setup, or when you have not properly exited (i.e., by pressing RESET) from a Program or Run menu.

The error can also occur when you upgrade SmartPAC PRO. Sometimes the information in the older firmware does not synchronize properly with the information in the new firmware. Settings can also be damaged due to an internal SmartPAC PRO malfunction.

SmartPAC PRO creates a “checksum” for every tool to check that the tool settings stored in memory are the same as the settings that are loaded with the tool. The checksum value calculated when tool settings are stored in memory must be the same as the value calculated when the settings are loaded.

Remedy: Access Program mode, and double-check the tool settings. If settings are correct, reload the tool.

If the error was caused because the system was turned off while in Program or Run modes, perform these steps:

1. Press RESET to clear the fault message.
2. Access Program mode, and select GO TO THE TOOL MANAGER.
3. On the Tool Manager screen, highlight the tool, and press EDIT TOOL.
4. On the Tool Program Menu, select CAM SWITCH.
5. Press RESET. SmartPAC PRO will create a new checksum for the tool.

6. Select the tool again, access the Tool Program Menu, and select CAM SWITCH. Verify that all settings are correct.
7. Reload the tool. You should no longer get this fault message.

If the problem is due to a system malfunction, the tool settings will have to be created again from scratch. If this happens more than once, contact Wintriss Tech. Support for assistance.

“S30 Program memory checksum 1 fault”

Explanation: The program memory test 1 did not produce the proper test results.

Remedy: If this occurs multiple times it could signify a hardware failure. Contact Wintriss Tech Support.

“S31 Program memory checksum 2 fault”

Explanation: The program memory test 2 did not produce the proper test results.

Remedy: If this occurs multiple times it could signify a hardware failure. Contact Wintriss Tech Support.

Messages for Sensor Faults

“Green sensor missed”

Explanation: A green or green quick check sensor did not turn on during the Ready signal nor within 50 milliseconds after the end of the Ready signal. No stroke angle is displayed for this error since the sensor never turned on.

Remedy: Check for the malfunction that the sensor was supposed to detect (part ejection problem, misfeed, transfer problem, etc.). If a malfunction is not the cause, check to be sure that the Ready signal is set properly for this sensor. Check that a sensor is actually plugged into this input on the DSI 2. If no sensor is connected to a sensor input, that input must be set to UNUSED. Check connections between sensors and the controller.

“Green sensor actuated late”

Explanation: A green or green quick check sensor turned on within 50 milliseconds after the end of the Ready signal.

If a green or green quick check sensor does not come on during its Ready signal, SmartPAC PRO continues to look for the sensor signal. If it sees the sensor come on within 50 milliseconds after the Ready signal ends, this message displays. The angle at which the sensor turned on is shown in the message.

Remedy: Check for the malfunction the sensor was supposed to detect (like a part ejection problem or misfeed, etc.). Check that the Ready signal is set properly, and adjust if necessary.

“Green sensor failure”

Explanation: A green or green constant sensor has stayed on from the end of one Ready signal to the beginning of the Ready signal for the next stroke. No stroke angle is shown with this fault.

Remedy: Check for a shorted sensor. Make sure the Ready signal has been set correctly. Check to see if a press or equipment malfunction is causing the sensor to stay on – for instance, a pinched wire or a part wedged against a sensor.

“Green constant fault”

Explanation: A green constant sensor turned off during its Ready signal. Green constant sensors must stay on throughout the Ready signal. The angle at which the sensor turned off is displayed.

Remedy: Check for the malfunction that the sensor was supposed to detect.

If no malfunction has occurred, check to make sure that the Ready signal is set properly. Remember, for green constant sensors, the Ready signal must be a little shorter than the sensor’s actuation angle. Check that a sensor is actually plugged into this input. Check connections between the DSI 2 and the controller.

“Green quick check sensor actuated outside ready”

Explanation: A green quick check sensor actuated or stayed on outside the Ready signal. The stroke angle at which the sensor was first detected on outside the Ready signal is shown.

Remedy: Check for the malfunction the sensor was supposed to detect (part ejection problem, misfeed, etc.). Check for a part wedged against the sensor, a shorted sensor, a pinched wire, or other cause that would keep the sensor on or cause it to go on outside its Ready signal. Make sure the Ready signal is set correctly.

“Green special fault”

Explanation: A green special sensor did not actuate (i.e., there was no contact closure to ground) within the maximum number of strokes set in Program mode.

Remedy: Check for the press or equipment malfunction that the sensor was supposed to detect. Check for any cause that would keep the sensor from going on. Make sure the maximum stroke count is set correctly, especially that it is not set too low. See *Setting the Counter Value for a Green Special Sensor* in

Chapter 6 of your SmartPAC PRO user manual.

Fault message for yellow sensors “This N/O sensor is grounded”

Explanation: A yellow sensor turned on (i.e., there was a contact closure to ground). When this message is displayed, the angle at which the condition was detected is shown.

Remedy: Check for the press or equipment malfunction that the sensor was supposed to detect. If no malfunction has occurred, check for a shorted sensor or pinched wire.

Fault message for red sensors “This N/C sensor is open”

Explanation: A red sensor has actuated (i.e., is open to ground). When this message is displayed, the angle at which the condition was detected is shown.

Remedy: Check for the press or equipment malfunction that the sensor was supposed to detect. If no malfunction has occurred, check for a problem with the sensor. Check for loose or detached wiring at the DSI 2 or controller. Check for a severed wire from the sensor to the DSI 2 or controller.

Miscellaneous Fault Messages

“S00 Maximum press speed exceeded”

Explanation: The press is running at a speed greater than the maximum limit programmed for this tool.

Remedy: After clearing the error, either run the press at a slower speed, or adjust the limit set in Program mode (see *PRESS SPEED* in Chapter 4 of your SmartPAC PRO user manual).

“S01 Minimum press speed exceeded”

Explanation: The press is running at a speed less than the minimum limit programmed for this tool.

Remedy: After clearing the error, either run the press at a higher speed, or adjust the limit set in Program mode (see *PRESS SPEED* in Chapter 4 of your SmartPAC PRO user manual).

“S33 The resolver position is different from when the unit was turned off ES”

Explanation: This message will only appear if SmartPAC PRO detects that the resolver angle when the press is turned on is different from the angle

when the press was turned off. This can happen when you move the press or upgrade SmartPAC PRO firmware.

Remedy: Press RESET to clear. If the message reappears, call Wintriss Tech. Support

“One of the sensor auto enable counters is greater than 99”

Explanation: Normally, this fault will never occur since SmartPAC PRO does not let you enter a value greater than 99. However, this message could display if there is an internal problem with SmartPAC PRO.

Remedy: First press RESET. If the message reappears, contact Wintriss Tech. Support.

“S32 Module communications fault”

Explanation: The SmartPAC PRO and the remote module at the following address are not communicating properly. - AA.

Where AA is the module address

- 1 - First AutosetPAC or WaveformPAC
- 2 - Second AutosetPAC or WaveformPAC
- 3 - Bruderer RamPAC (Old MultiPAC)
- 4 - RamPAC
- 5 - First ProPAC
- 6 - Second ProPAC

Remedy: Make sure the module in question is powered up and verify the wiring is correct per installation diagram.

“S35 Loss of Communication at Address X ES”

Explanation: SmartPAC PRO is unable to communicate with the optional module identified by “X” in the message (see Table 8-1).

Remedy: Check the wiring of the specified module. If you continue to get this error message, call Wintriss Tech. Support.

Table 8-1. Communication Errors: SmartPAC PRO Option Identified by Address Number

| Message | Option Identified by Address |
|------------------------------------|---------------------------------------------|
| Loss of Communication at Address 1 | AutoSetPAC or WaveFormPAC Channels 1 - 4 |
| Loss of Communication at Address 2 | AutoSetPAC or WaveFormPAC Channels 5 - 8 |
| Loss of Communication at Address 4 | RamPAC |
| Loss of Communication at Address 5 | ProPAC |

CAN Bus Fault Message

No CAN Connection Detected

Explanation: The CAN cable is loose or not connected properly between TB6 on the HMI board and TB1 on the RTS board.

Remedy: Check the cable connection. After you secure the connection, you may need to cycle the power to clear the fault.

Additional Miscellaneous Fault Codes

If any of the following faults occur, contact Wintriss Tech. Support.

S29 - EStop relay drivers failed the drop out test

S38 - PLC interface estop error ES

S39 - DiProPAC auto enable counter error ES

S40 - STI, FeedRite, Tool number interface not communicating error ES

S43 - Dialog code backfill ES

S44 - Tool ID mismatch error ES

Troubleshooting Using the Error/Event Log

The Error/Event Log, which you can view in Run mode, is a useful troubleshooting aid. You can use the Error/Event log to help you diagnose the cause of a problem, or you can send the log to Wintriss Tech. Support to help them narrow down probable causes. For more information, see *ERROR/EVENT LOG* in Chapter 5 of your SmartPAC PRO user manual, and the Message button in Chapter 1.

SmartPAC PRO Setup Sheet

Tool Name and Number: _____

Counter Presets

| | Batch 1 (Ch. 6) | Batch 2 (Ch. 7) | Batch 3 (Ch. 8) |
|----------------------------------------|--------------------------------------------|--------------------------------------------|--------------------------------------------|
| Preset Value | | | |
| Output mode (circle one) | Top Stop Toggle Pulse for _____mS | Top Stop Toggle Pulse for _____mS | Top Stop Toggle Pulse for _____mS |
| Increment mode (circle one) | Strokes Good Parts | Strokes Good Parts | Strokes Good Parts |
| Increment angle (degrees) | | | |

This tool should be serviced when the TOTAL HITS count reaches _____

Strokes / Part: _____ - OR - Parts / Stroke: _____

Tool Information

| Item | Value | Units |
|------|-------|-------|
| | | |
| | | |
| | | |
| | | |
| | | |
| | | |

Tool Memo box text
(30 characters, total)

| |
|---------------------------|
| <p>-----</p> <p>-----</p> |
|---------------------------|

ProCamPAC Cam Switch – SmartPAC PRO Setup Sheet Channels 1-8

Tool Name and Number: _____

| Ch # | Cam Name (function) same for all tools | Global cam? (✓) Not Ch. 6, 7 or 8 | Auto Adv.? (✓) 2 max. Program ON/OFF angles | TIMED 4 max. ON angle + ON Time in mS | DSV-ON Time to shut-off after press stops, in seconds | ON/OFF Multiple arcs for ON/OFF only 6 extras, total | | |
|------|-------------------------------------------|--------------------------------------------------|---------------------------------------------------------------|------------------------------------------------------|-------------------------------------------------------------------------|--------------------------------------------------------------|-------------|--------------|
| | | | | | | Arc # Normally 1 arc per channel, can be up to 4 | ON angle | OFF angle |
| 1 | | | | ____ ° ____ mS | ____ sec | Arc 1 | | |
| | | | | | | Arc 2 | | |
| | | | | | | Arc 3 | | |
| | | | | | | Arc 4 | | |
| 2 | | | | ____ ° ____ mS | ____ sec | Arc 1 | | |
| | | | | | | Arc 2 | | |
| | | | | | | Arc 3 | | |
| | | | | | | Arc 4 | | |
| 3 | | | | ____ ° ____ mS | ____ sec | Arc 1 | | |
| | | | | | | Arc 2 | | |
| | | | | | | Arc 3 | | |
| | | | | | | Arc 4 | | |
| 4 | | | | ____ ° ____ mS | ____ sec | Arc 1 | | |
| | | | | | | Arc 2 | | |
| | | | | | | Arc 3 | | |
| | | | | | | Arc 4 | | |
| 5 | | | | ____ ° ____ mS | ____ sec | Arc 1 | | |
| | | | | | | Arc 2 | | |
| | | | | | | Arc 3 | | |
| | | | | | | Arc 4 | | |
| 6 | | | | ____ ° ____ mS | ____ sec | Arc 1 | | |
| | | | | | | Arc 2 | | |
| | | | | | | Arc 3 | | |
| | | | | | | Arc 4 | | |
| 7 | | | | ____ ° ____ mS | ____ sec | Arc 1 | | |
| | | | | | | Arc 2 | | |
| | | | | | | Arc 3 | | |
| | | | | | | Arc 4 | | |
| 8 | | | | ____ ° ____ mS | ____ sec | Arc 1 | | |
| | | | | | | Arc 2 | | |
| | | | | | | Arc 3 | | |
| | | | | | | Arc 4 | | |

ProCamPAC Cam Switch – SmartPAC PRO Setup Sheet Channels 9-16

Tool Name and Number: _____

| Ch # | Cam Name (function) same for all tools | Global cam? (✓) Not Ch. 6, 7 or 8 | Auto Adv.? (✓) 2 max. Program ON/OFF angles | TIMED 4 max. ON angle + ON Time in mS | DSV-ON Time to shut-off after press stops, in seconds | ON/OFF Multiple arcs for ON/OFF only 6 extras, total | | |
|------|-------------------------------------------|--------------------------------------------------|---------------------------------------------------------------|------------------------------------------------------|-------------------------------------------------------------------------|-----------------------------------------------------------------|-------------|--------------|
| | | | | | | Arc # Normally 1 arc per channel, can be up to 4 | ON angle | OFF angle |
| 9 | | | | ____ ° ____ mS | ____ sec | Arc 1 | | |
| | | | | | | Arc 2 | | |
| | | | | | | Arc 3 | | |
| | | | | | | Arc 4 | | |
| 10 | | | | ____ ° ____ mS | ____ sec | Arc 1 | | |
| | | | | | | Arc 2 | | |
| | | | | | | Arc 3 | | |
| | | | | | | Arc 4 | | |
| 11 | | | | ____ ° ____ mS | ____ sec | Arc 1 | | |
| | | | | | | Arc 2 | | |
| | | | | | | Arc 3 | | |
| | | | | | | Arc 4 | | |
| 12 | | | | ____ ° ____ mS | ____ sec | Arc 1 | | |
| | | | | | | Arc 2 | | |
| | | | | | | Arc 3 | | |
| | | | | | | Arc 4 | | |
| 13 | | | | ____ ° ____ mS | ____ sec | Arc 1 | | |
| | | | | | | Arc 2 | | |
| | | | | | | Arc 3 | | |
| | | | | | | Arc 4 | | |
| 14 | | | | ____ ° ____ mS | ____ sec | Arc 1 | | |
| | | | | | | Arc 2 | | |
| | | | | | | Arc 3 | | |
| | | | | | | Arc 4 | | |
| 15 | | | | ____ ° ____ mS | ____ sec | Arc 1 | | |
| | | | | | | Arc 2 | | |
| | | | | | | Arc 3 | | |
| | | | | | | Arc 4 | | |
| 16 | | | | ____ ° ____ mS | ____ sec | Arc 1 | | |
| | | | | | | Arc 2 | | |
| | | | | | | Arc 3 | | |
| | | | | | | Arc 4 | | |

DiProPAC Die Protection – SmartPAC PRO Setup Form Sensors 1-16

Tool Name and Number: _____

| Sensor Number | Sensor Name (function) | Sensor Type (circle one) | Stop Type (circle one) | Ready Signal Timing |
|---------------|------------------------|----------------------------------------------------|----------------------------------|---------------------|
| 1 | | R Y G GC GQ GS ___strokes GF | E-STOP TOP STOP SMART STOP | ON |
| | | | | OFF |
| 2 | | R Y G GC GQ GS ___strokes GF | E-STOP TOP STOP SMART STOP | ON |
| | | | | OFF |
| 3 | | R Y G GC GQ GS ___strokes GF | E-STOP TOP STOP SMART STOP | ON |
| | | | | OFF |
| 4 | | R Y G GC GQ GS ___strokes GF | E-STOP TOP STOP SMART STOP | ON |
| | | | | OFF |
| 5 | | R Y G GC GQ GS ___strokes GF | E-STOP TOP STOP SMART STOP | ON |
| | | | | OFF |
| 6 | | R Y G GC GQ GS ___strokes GF | E-STOP TOP STOP SMART STOP | ON |
| | | | | OFF |
| 7 | | R Y G GC GQ GS ___strokes GF | E-STOP TOP STOP SMART STOP | ON |
| | | | | OFF |
| 8 | | R Y G GC GQ GS ___strokes GF | E-STOP TOP STOP SMART STOP | ON |
| | | | | OFF |
| 9 | | R Y G GC GQ GS ___strokes GF | E-STOP TOP STOP SMART STOP | ON |
| | | | | OFF |
| 10 | | R Y G GC GQ GS ___strokes GF | E-STOP TOP STOP SMART STOP | ON |
| | | | | OFF |
| 11 | | R Y G GC GQ GS ___strokes GF | E-STOP TOP STOP SMART STOP | ON |
| | | | | OFF |
| 12 | | R Y G GC GQ GS ___strokes GF | E-STOP TOP STOP SMART STOP | ON |
| | | | | OFF |
| 13 | | R Y G GC GQ GS ___strokes GF | E-STOP TOP STOP SMART STOP | ON |
| | | | | OFF |
| 14 | | R Y G GC GQ GS ___strokes GF | E-STOP TOP STOP SMART STOP | ON |
| | | | | OFF |
| 15 | | R Y G GC GQ GS ___strokes GF | E-STOP TOP STOP SMART STOP | ON |
| | | | | OFF |
| 16 | | R Y G GC GQ GS ___strokes GF | E-STOP TOP STOP SMART STOP | ON |
| | | | | OFF |

Auto Enable

Counter

Critical Angle (for Smart Stop)

R=RED; Y=YELLOW; G=GREEN STD; GC=GREEN CONSTANT;
GQ=GREEN QUICK CHECK; GS=GREEN SPECIAL; GF=GREEN FLEX

DiProPAC Die Protection – SmartPAC PRO Setup Form Sensors 17-32

Tool Name and Number: _____

| Sensor Number | Sensor Name (function) | Sensor Type (circle one) | Stop Type (circle one) | Ready Signal Timing |
|---------------|------------------------|------------------------------------------------------------|----------------------------------|---------------------|
| 17 | | R Y G GC GQ GS ___strokes GF | E-STOP TOP STOP SMART STOP | ON |
| | | OFF | | |
| 18 | | R Y G GC GQ GS ___strokes GF | E-STOP TOP STOP SMART STOP | ON |
| | | OFF | | |
| 19 | | R Y G GC GQ GS ___strokes GF | E-STOP TOP STOP SMART STOP | ON |
| | | OFF | | |
| 20 | | R Y G GC GQ GS ___strokes GF | E-STOP TOP STOP SMART STOP | ON |
| | | OFF | | |
| 21 | | R Y G GC GQ GS ___strokes GF | E-STOP TOP STOP SMART STOP | ON |
| | | OFF | | |
| 22 | | R Y G GC GQ GS ___strokes GF | E-STOP TOP STOP SMART STOP | ON |
| | | OFF | | |
| 23 | | R Y G GC GQ GS ___strokes GF | E-STOP TOP STOP SMART STOP | ON |
| | | OFF | | |
| 24 | | R Y G GC GQ GS ___strokes GF | E-STOP TOP STOP SMART STOP | ON |
| | | OFF | | |
| 25 | | R Y G GC GQ GS ___strokes GF | E-STOP TOP STOP SMART STOP | ON |
| | | OFF | | |
| 26 | | R Y G GC GQ GS ___strokes GF | E-STOP TOP STOP SMART STOP | ON |
| | | OFF | | |
| 27 | | R Y G GC GQ GS ___strokes GF | E-STOP TOP STOP SMART STOP | ON |
| | | OFF | | |
| 28 | | R Y G GC GQ GS ___strokes GF | E-STOP TOP STOP SMART STOP | ON |
| | | OFF | | |
| 29 | | R Y G GC GQ GS ___strokes GF | E-STOP TOP STOP SMART STOP | ON |
| | | OFF | | |
| 30 | | R Y G GC GQ GS ___strokes GF | E-STOP TOP STOP SMART STOP | ON |
| | | OFF | | |
| 31 | | R Y G GC GQ GS ___strokes GF | E-STOP TOP STOP SMART STOP | ON |
| | | OFF | | |
| 32 | | R Y G GC GQ GS ___strokes GF | E-STOP TOP STOP SMART STOP | ON |
| | | OFF | | |

Auto Enable Counter

Critical

Angle (for Smart Stop)

R=RED; Y=YELLOW; G=GREEN STD; GC=GREEN CONSTANT;
 GQ=GREEN QUICK CHECK; GS=GREEN SPECIAL; GF=GREEN FLEX

| REVISIONS | | | |
|-----------|-------------|------|-------|
| REV | DESCRIPTION | DATE | APP'D |
| | | | |

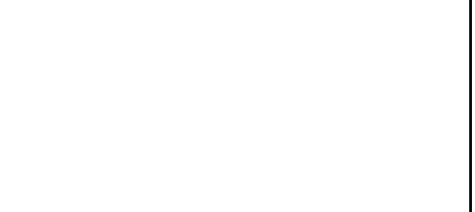
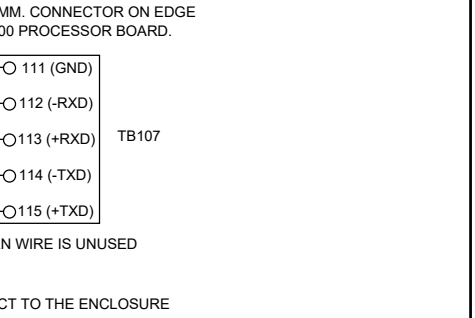
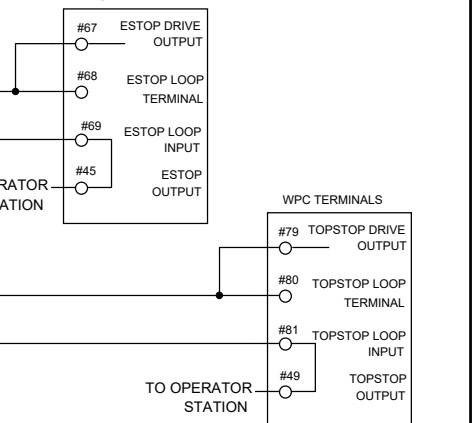
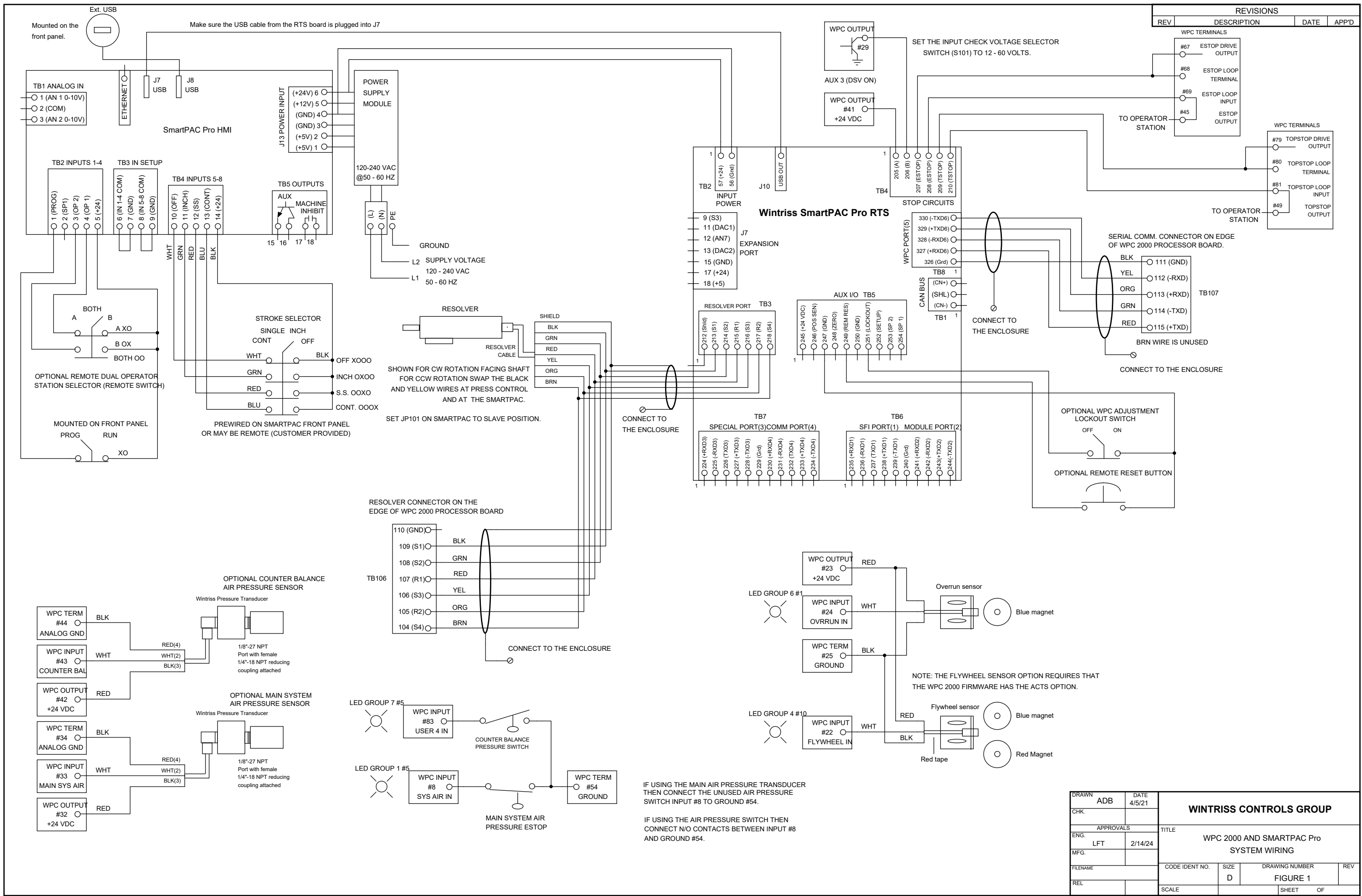

| | | | | | | |
|-----------|-----|------|---------|-----------------------------------------|------|----------------|
| DRAWN | ADB | DATE | 4/5/21 | WINTRISS CONTROLS GROUP | | |
| CHK. | | | | | | |
| APPROVALS | | | | TITLE | | |
| ENG. | LFT | DATE | 2/14/24 | WPC 2000 AND SMARTPAC Pro SYSTEM WIRING | | |
| MFG. | | | | CODE IDENT NO. | SIZE | DRAWING NUMBER |
| FILENAME | | | | | D | FIGURE 1 |
| REL | | | | SCALE | | SHEET OF |

IF USING THE MAIN AIR PRESSURE TRANSDUCER THEN CONNECT THE UNUSED AIR PRESSURE SWITCH INPUT #8 TO GROUND #54.

IF USING THE AIR PRESSURE SWITCH THEN CONNECT N/O CONTACTS BETWEEN INPUT #8 AND GROUND #54.

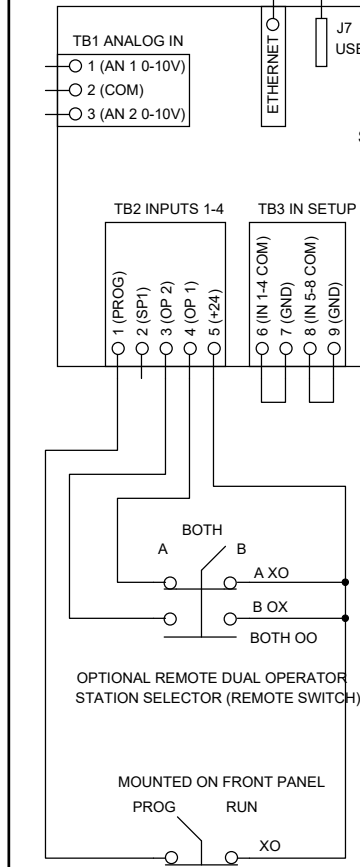
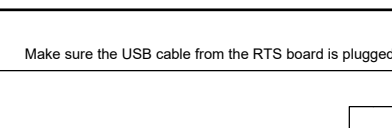
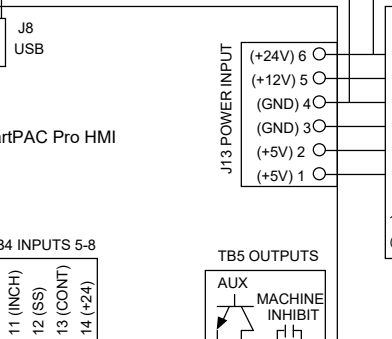
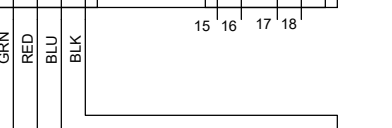
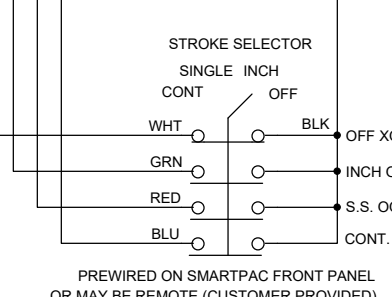
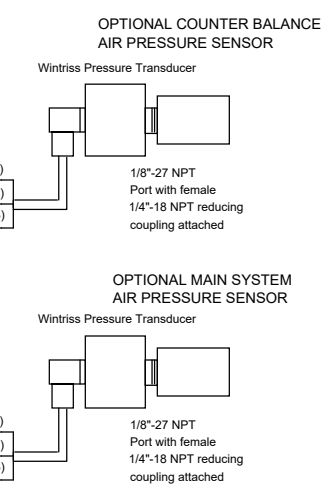
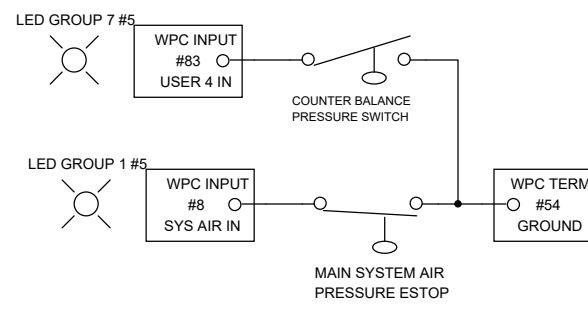
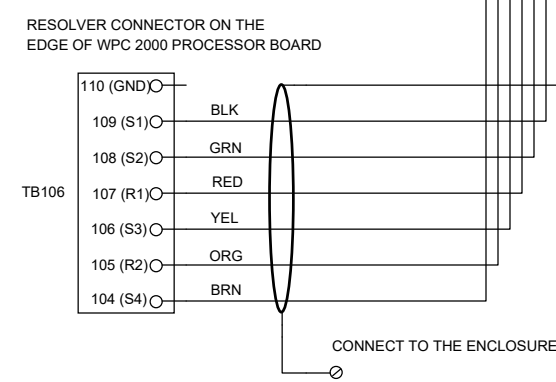

| REVISIONS | | | |
|-----------|-------------|------|-------|
| REV | DESCRIPTION | DATE | APP'D |
| | | | |

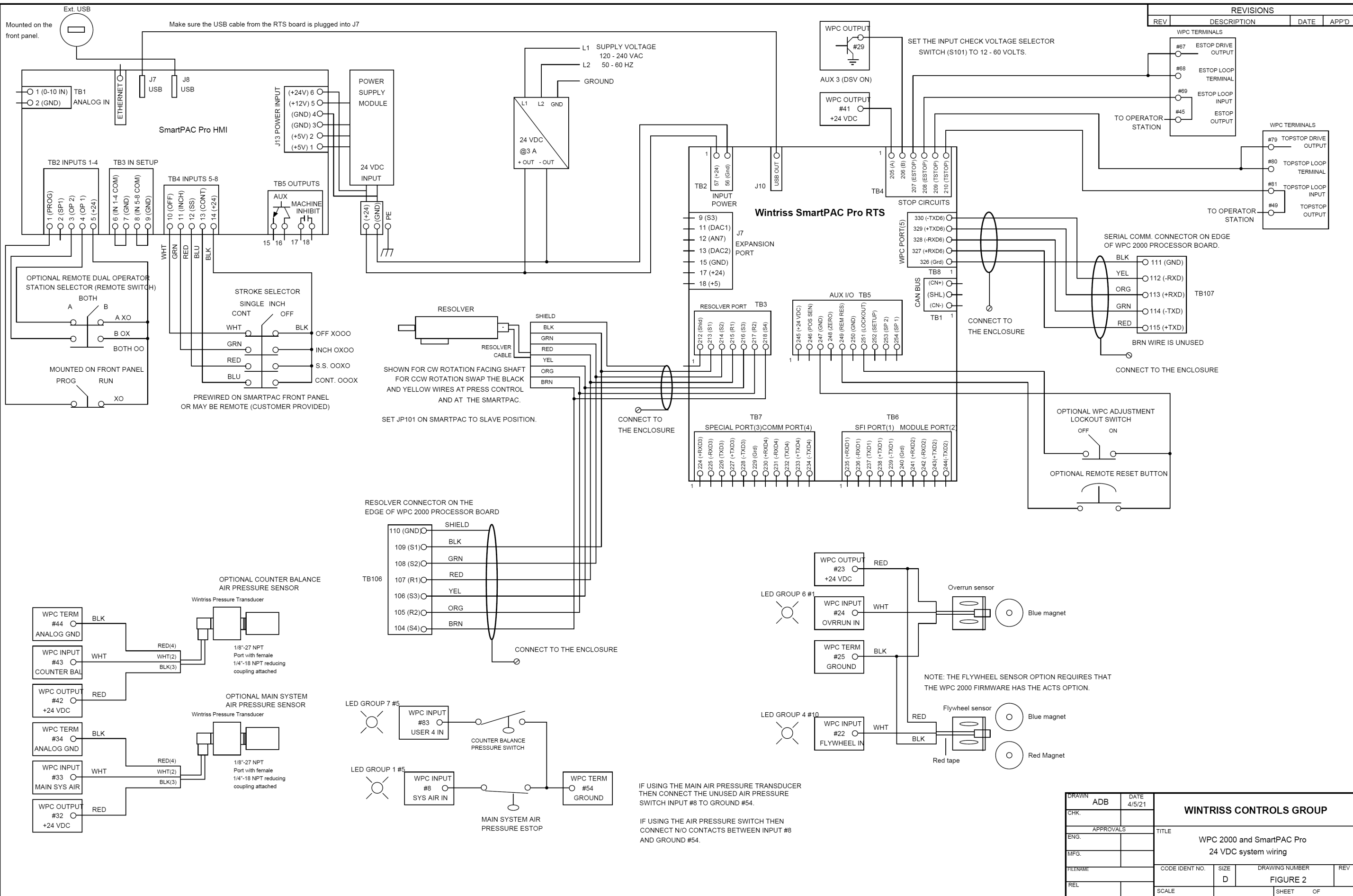

| | | | | | | | | | |
|-----------|-----|------|--------|--------------------------------|------|----------------|------------------------------------------------------------|--|--|
| DRAWN | ADB | DATE | 4/5/21 | WINTRISS CONTROLS GROUP | | | | | |
| CHK. | | | | | | | | | |
| APPROVALS | | | | | | | TITLE WPC 2000 and SmartPAC Pro 24 VDC system wiring | | |
| ENG. | | | | | | | | | |
| MFG. | | | | CODE IDENT NO. | SIZE | DRAWING NUMBER | REV | | |
| FILENAME | | | | | D | FIGURE 2 | | | |
| REL | | | | SCALE | | SHEET | OF | | |

IF USING THE MAIN AIR PRESSURE TRANSDUCER THEN CONNECT THE UNUSED AIR PRESSURE SWITCH INPUT #8 TO GROUND #54.

IF USING THE AIR PRESSURE SWITCH THEN CONNECT N/O CONTACTS BETWEEN INPUT #8 AND GROUND #54.

PROPRIETARY RIGHTS. This document discloses subject matter in which Wintriss Controls Group has proprietary rights. Neither receipt nor possession thereof confers or transfers any right to reproduce or disclose the document, any part thereof, any information contained therein or any physical article or device, or to practice any method or process, except by written permission or written agreement with Wintriss Controls Group.

| REVISIONS | | | |
|-----------|-------------|------|-------|
| REV | DESCRIPTION | DATE | APP'D |

CAMS 1 - 8

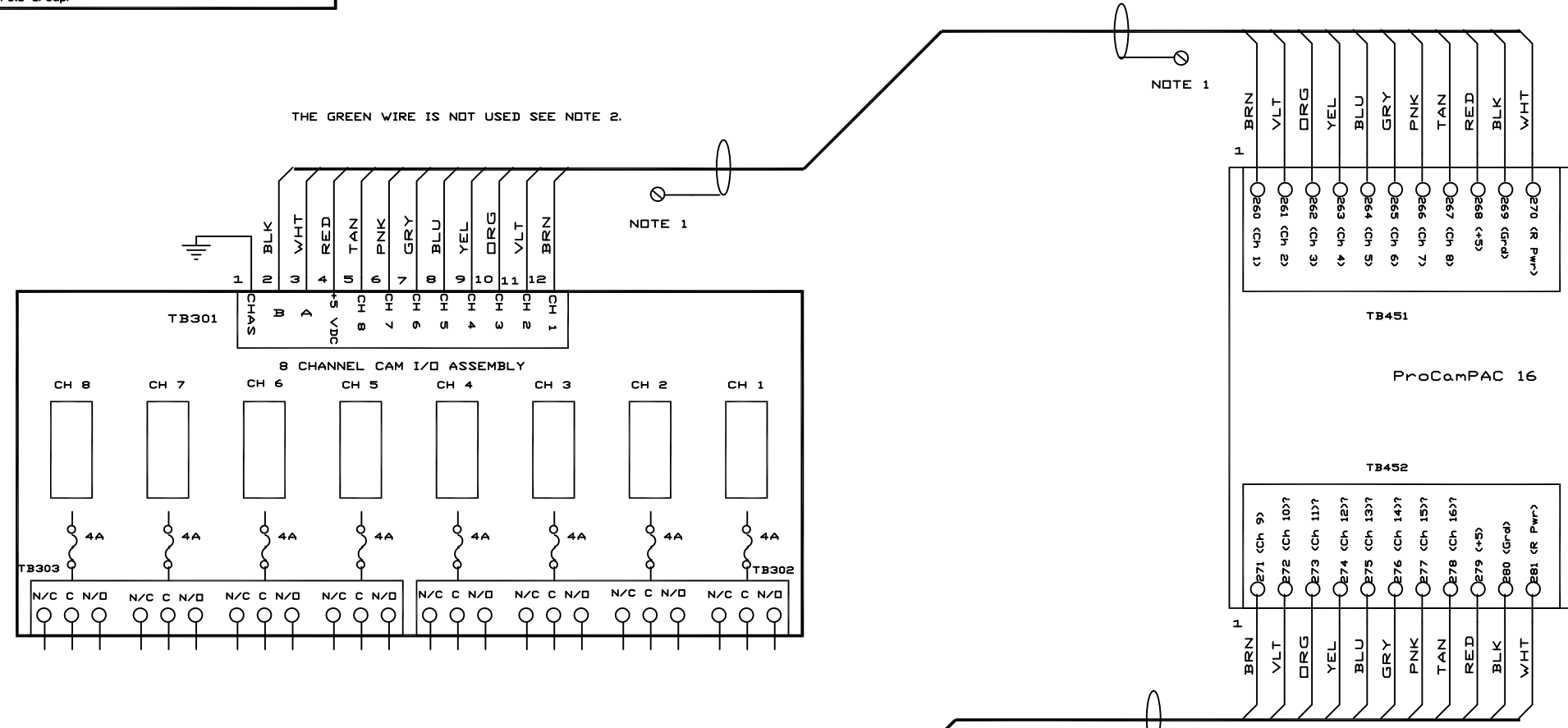

CAMS 9 - 16

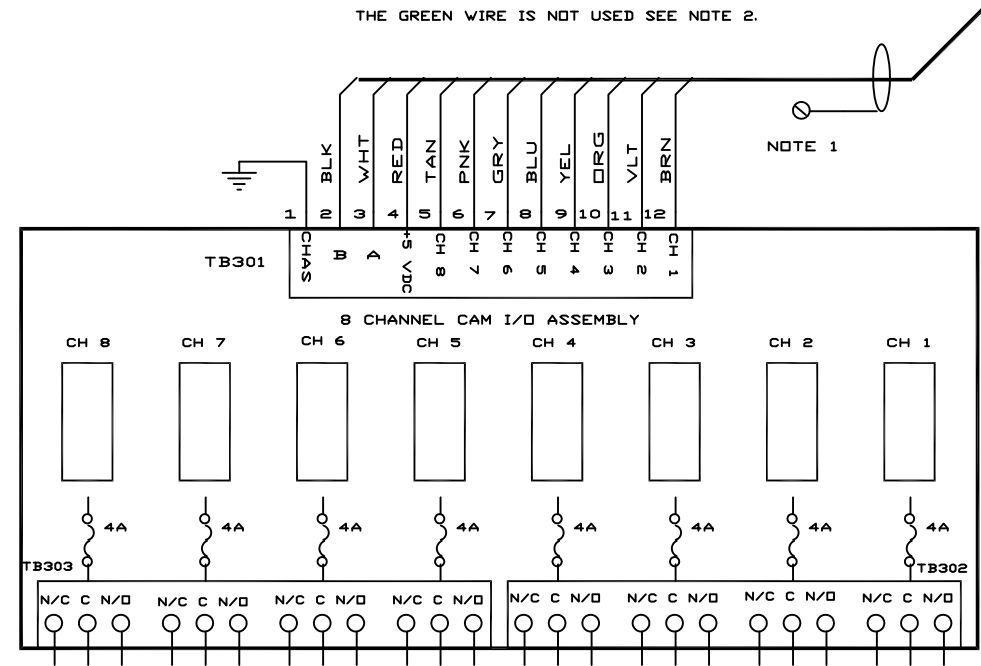

NOTE 1: TERMINATE THE SHIELD TO THE ENCLOSURE CLOSE TO THE CONDUIT ENTRY POINT.

NOTE 2: CUT OFF THE GREEN WIRE FLUSH WITH THE END OF THE CABLE JACKET.

| | | | | |
|--------------|-----------------|-------------------------------------------------------|-----------|----------------------------|
| DRAWN ADB | DATE 7/10/14 | WINTRISS CONTROLS GROUP | | |
| CHK. | | TITLE ProCamPAC 16 to Cam Output Wiring Diagram | | |
| APPROVALS | | | | |
| ENG. | | | | |
| MFG. | | | | |
| FILENAME | | CODE IDENT NO. | SIZE C | DRAWING NUMBER FIGURE 3 |
| REL | | SCALE | SHEET OF | |

PROPRIETARY RIGHTS. This document discloses subject matter in which Wintriss Controls Group has proprietary rights. Neither receipt nor possession thereof confers or transfers any right to reproduce or disclose the document, any part thereof, any information contained therein or any physical article or device, or to practice any method or process, except by written permission or written agreement with Wintriss Controls Group.

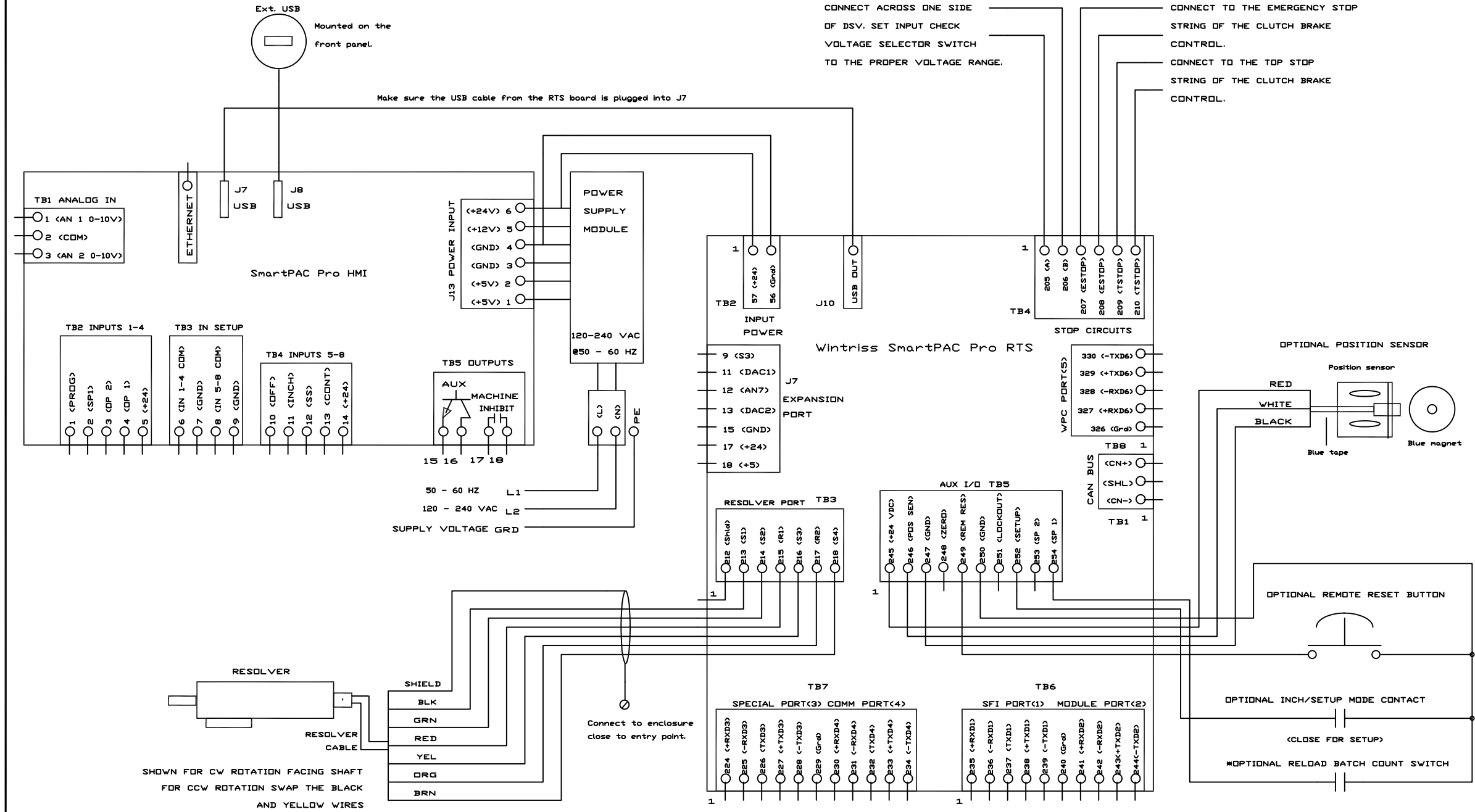

| | | | |
|----------------------------------------------------|---------|----------------|-----|
| TITLE | | | |
| 120 - 240 VAC SmartPAC Pro wiring configuration | | | |
| DRAWN | SIZE | DRAWING NUMBER | REV |
| ADB | C | FIGURE 4 | |
| DATE | 8/28/20 | SHEET | OF |

*Contact Wintriss Tech. Support for details

PROPRIETARY RIGHTS. This document discloses subject matter in which Wintriss Controls Group has proprietary rights. Neither receipt nor possession thereof confers or transfers any right to reproduce or disclose the document, any part thereof, any information contained therein or any physical article or device, or to practice any method or process, except by written permission or written agreement with Wintriss Controls Group.

| REVISIONS | | | |
|-----------|-------------|------|-------|
| REV | DESCRIPTION | DATE | APP'D |

RS 485 CONNECTIONS

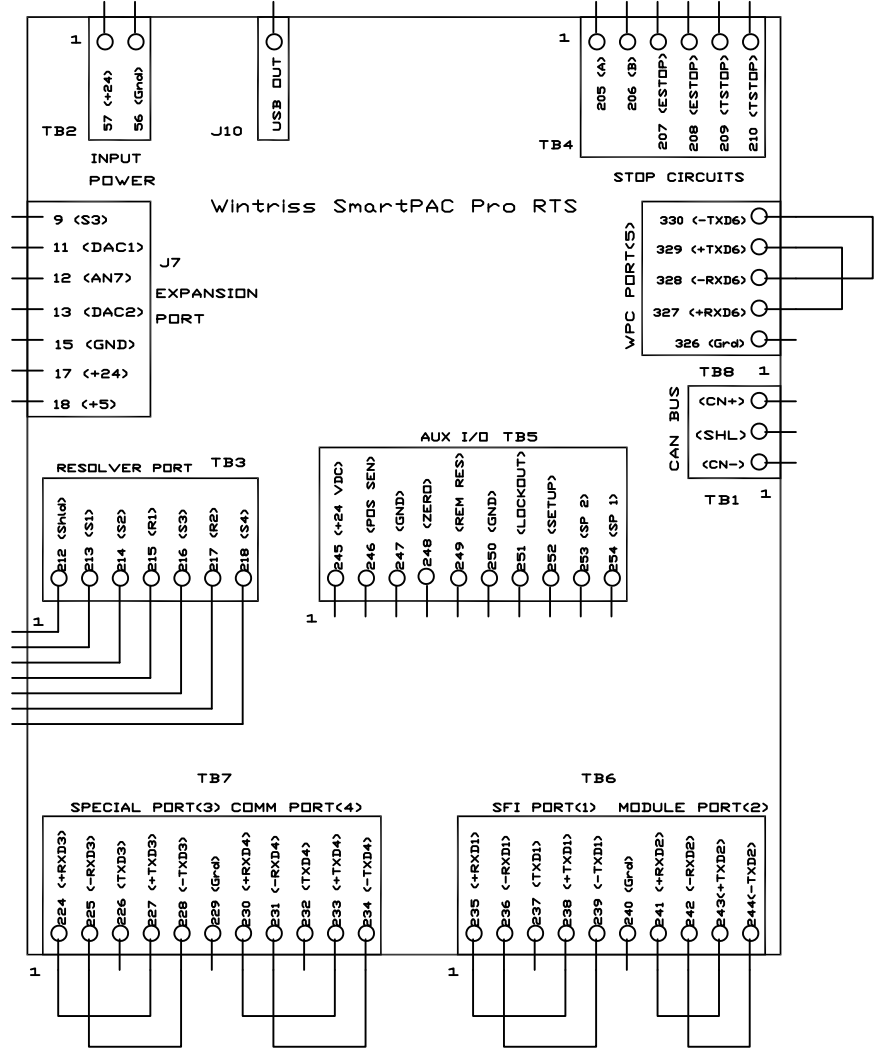

RS 232 CONNECTIONS

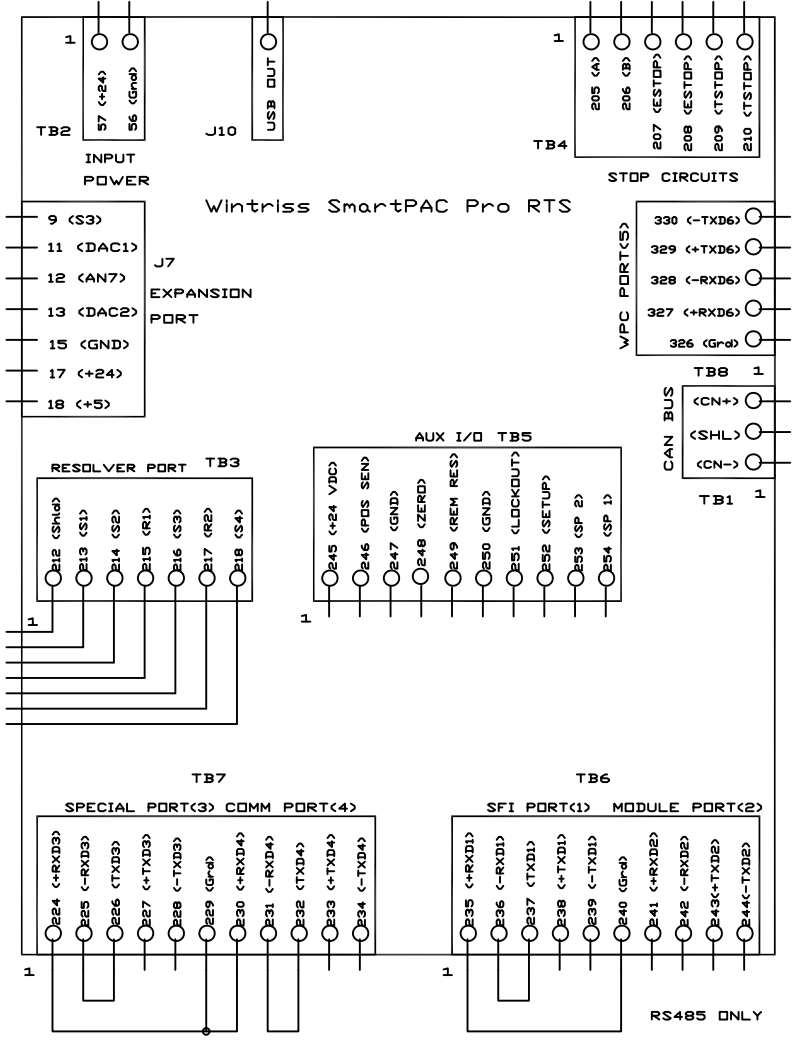

RS485 ONLY

RS485 ONLY

| | | | | |
|--------------|-----------------|-----------------------------------|-----------|----------------------------|
| DRAWN ADB | DATE 2/26/19 | WINTRISS CONTROLS GROUP | | |
| CHK. | | TITLE | | |
| APPROVALS | | SmartPAC Pro loopback test wiring | | |
| ENG. | | CODE IDENT NO. | SIZE C | DRAWING NUMBER FIGURE 5 |
| MFG. | | REL | SCALE | REV |
| | | SHEET | | OF |

PROPRIETARY RIGHTS. This document discloses subject matter in which Wintriss Controls Group has proprietary rights. Neither receipt nor possession thereof confers or transfers any right to reproduce or disclose the document, any part thereof, any information contained therein or any physical article or device, or to practice any method or process, except by written permission or written agreement with Wintriss Controls Group.

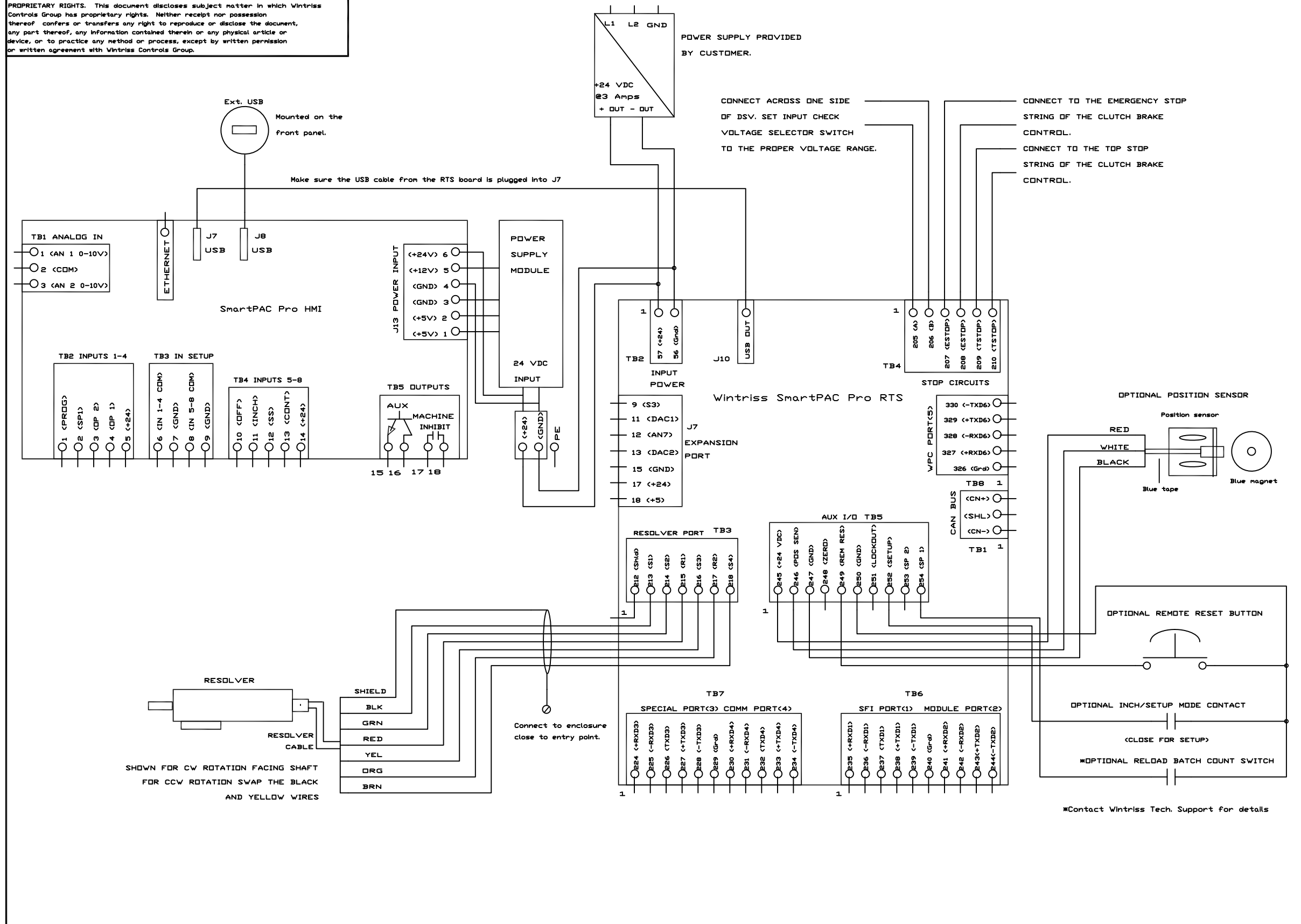

| | | | |
|----------------------|---------|----------------|-----|
| TITLE | | | |
| +24 VDC SmartPAC Pro | | | |
| wiring configuration | | | |
| DRAWN | SIZE | DRAWING NUMBER | REV |
| ADB | C | FIGURE 6 | |
| DATE | 8/28/20 | SHEET | OF |

PROPRIETARY RIGHTS. This document discloses subject matter in which Wintriss Controls Group has proprietary rights. Neither receipt nor possession thereof confers or transfers any right to reproduce or disclose the document, any part thereof, any information contained therein or any physical article or device, or to practice any method or process, except by written permission or written agreement with Wintriss Controls Group.

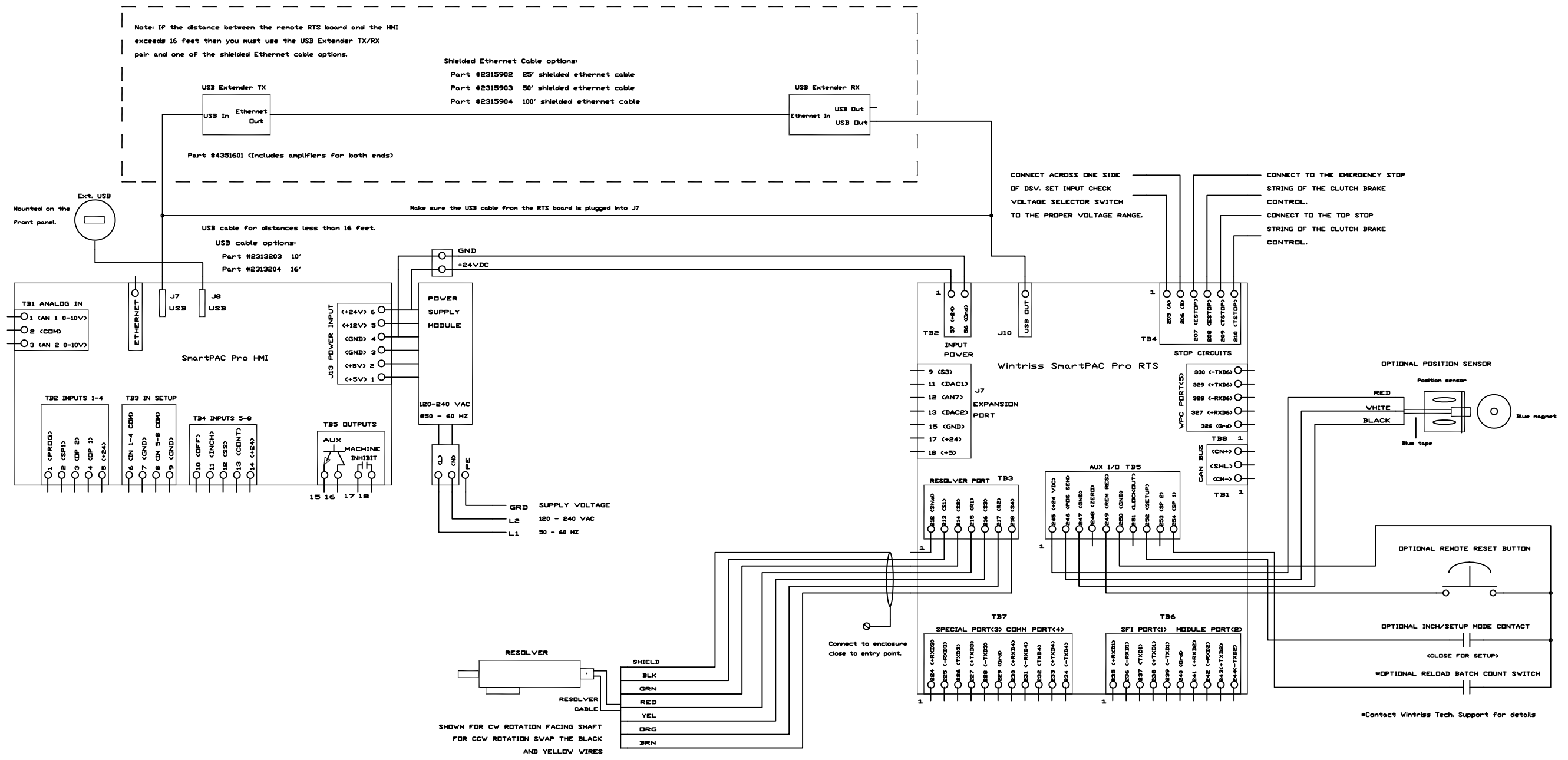

| | | | | | |
|-----------|-----|----------------|----------------------------------------------------------------------|----------------|-----|
| DRAWN | ADB | DATE | 8/28/20 | | |
| CHK. | | | WINTRISS CONTROLS GROUP | | |
| APPROVALS | | TITLE | 120 - 240 VAC SmartPAC Pro with USB extended wiring configuration | | |
| ENG. | | CODE IDENT NO. | SIZE | DRAWING NUMBER | REV |
| MFG. | | | D | FIGURE 7 | |
| FILENAME | | SCALE | | SHEET | OF |
| REL | | | | | |

PROPRIETARY RIGHTS. This document discloses subject matter in which Wintriss Controls Group has proprietary rights. Neither receipt nor possession thereof confers or transfers any right to reproduce or disclose the document, any part thereof, any information contained therein or any physical article or device, or to practice any method or process, except by written permission or written agreement with Wintriss Controls Group.

Note: If the distance between the remote RTS board and the HMI exceeds 16 feet then you must use the USB Extender TX/RX pair and one of the shielded Ethernet cable options.

Shielded Ethernet Cable options:
 Part #2315902 25' shielded ethernet cable
 Part #2315903 50' shielded ethernet cable
 Part #2315904 100' shielded ethernet cable

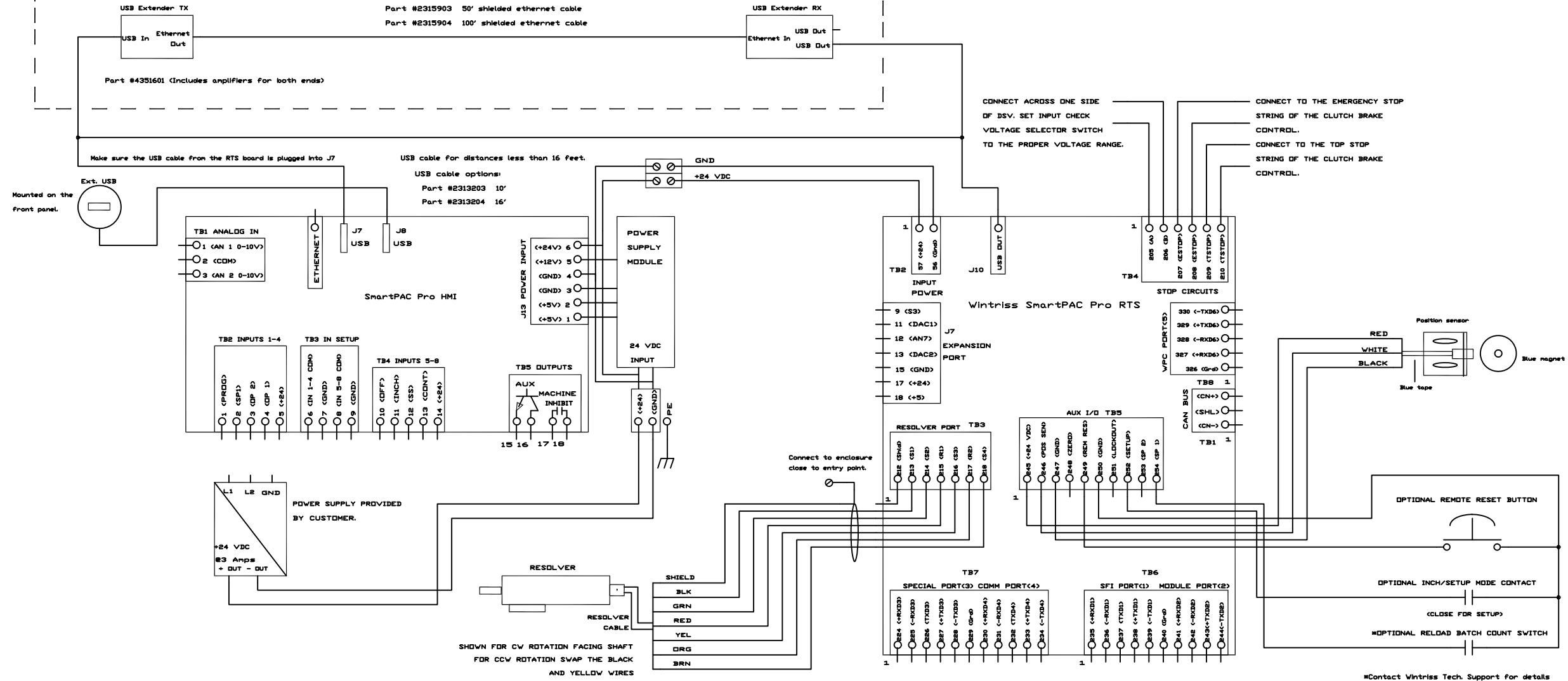

| | | | | | | | |
|-----------|-----|----------------|---------|---------------------------------------------------------------|-----|--|--|
| DRAWN | ADB | DATE | 8/28/20 | WINTRISS CONTROLS GROUP | | | |
| CHK. | | | | | | | |
| APPROVALS | | | | TITLE | | | |
| ENG. | | | | 24 VDC SmartPAC Pro with USB extended wiring configuration | | | |
| MFG. | | | | | | | |
| FILENAME | | CODE IDENT NO. | SIZE | DRAWING NUMBER | REV | | |
| REL | | | D | FIGURE 8 | | | |
| SCALE | | | | SHEET OF | | | |

PROPRIETARY RIGHTS. This document discloses subject matter in which Wintriss Controls Group has proprietary rights. Neither receipt nor possession thereof confers or transfers any right to reproduce or disclose the document, any part thereof, any information contained therein or any physical article or device, or to practice any method or process, except by written permission or written agreement with Wintriss Controls Group.

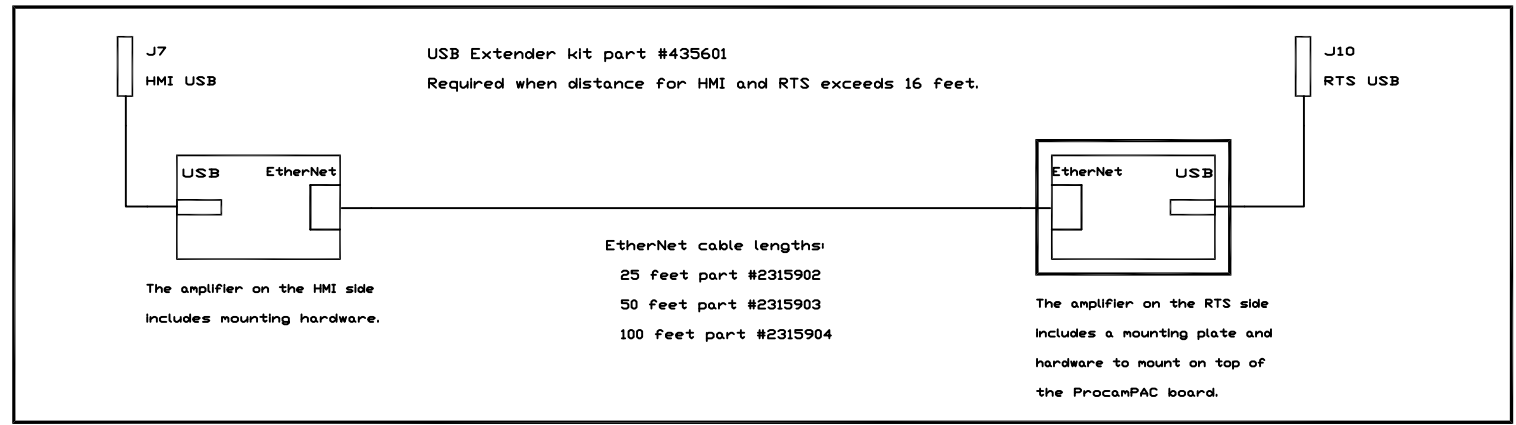
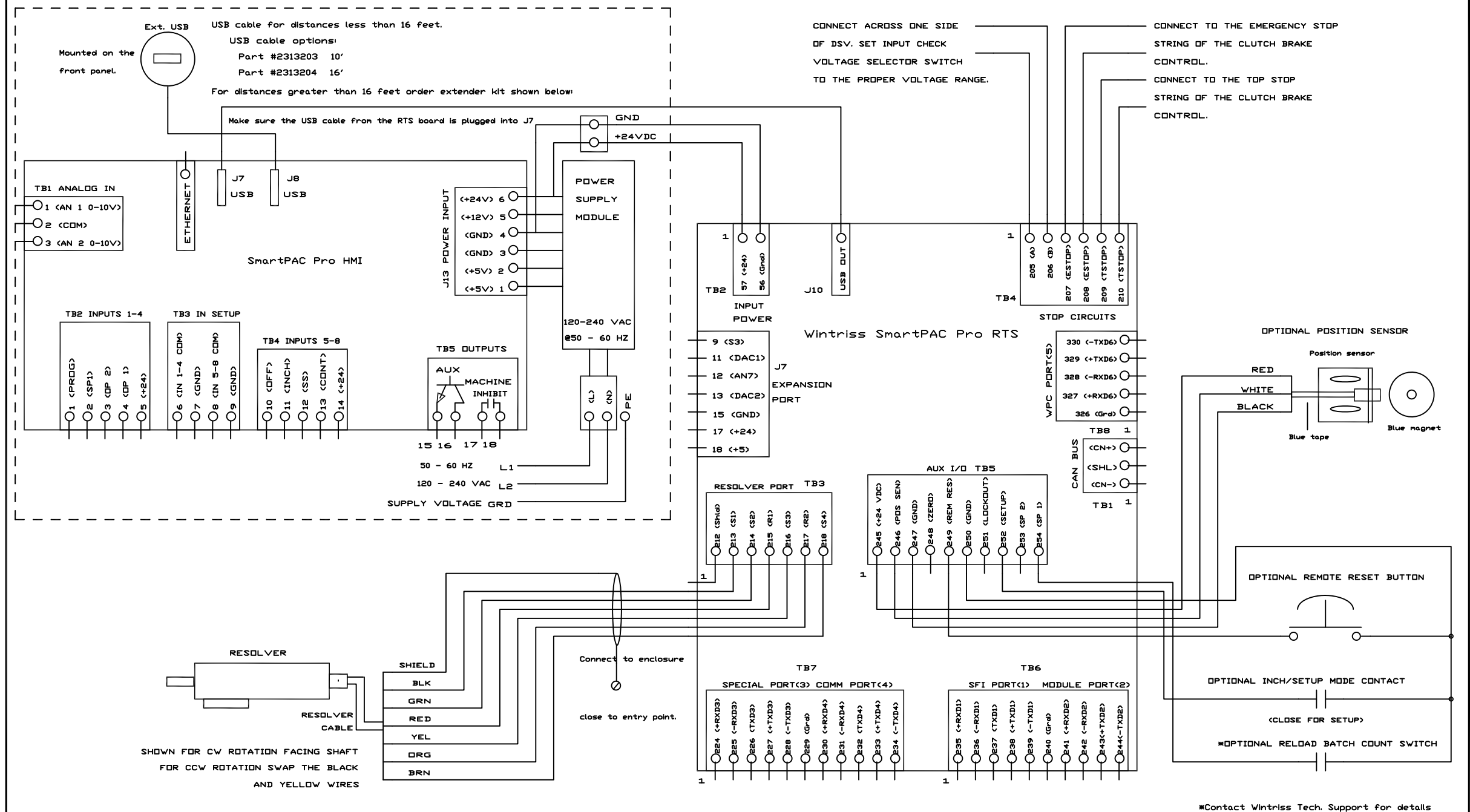

| | | | |
|--------------------------------------------------------------------------|-----------|----------------------------|-----|
| TITLE 120 - 240 VAC SmartPAC Pro with remote RTS wiring configuration | | | |
| DRAWN ADB | SIZE C | DRAWING NUMBER FIGURE 9 | REV |
| DATE 8/28/20 | SHEET | | OF |

PROPRIETARY RIGHTS. This document discloses subject matter in which Wintriss Controls Group has proprietary rights. Neither receipt nor possession thereof confers or transfers any right to reproduce or disclose the document, any part thereof, any information contained therein or any physical article or device, or to practice any method or process, except by written permission or written agreement with Wintriss Controls Group.

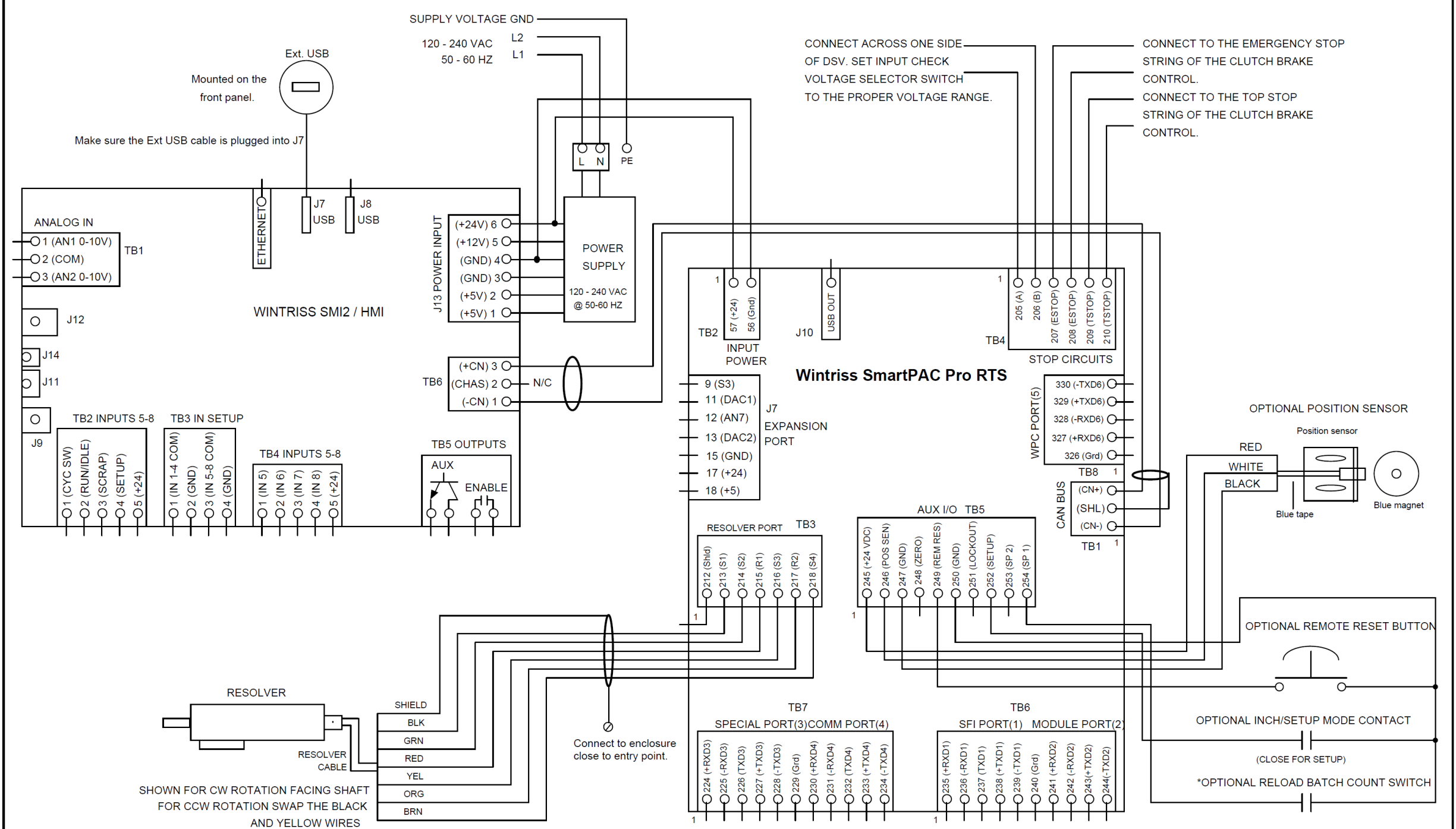

*Contact Wintriss Tech. Support for details

| | | | |
|--------------------------------|----------|----------------|-----|
| TITLE | | | |
| 120 - 240 VAC SmartPAC Pro | | | |
| Wiring configuration w/CAN bus | | | |
| DRAWN | SIZE | DRAWING NUMBER | REV |
| ADB/LFT | C | FIGURE 10 | |
| DATE | 10/18/23 | SHEET | OF |

PROPRIETARY RIGHTS. This document discloses subject matter in which Wintriss Controls Group has proprietary rights. Neither receipt nor possession thereof confers or transfers any right to reproduce or disclose the document, any part thereof, any information contained therein or any physical article or device, or to practice any method or process, except by written permission or written agreement with Wintriss Controls Group.

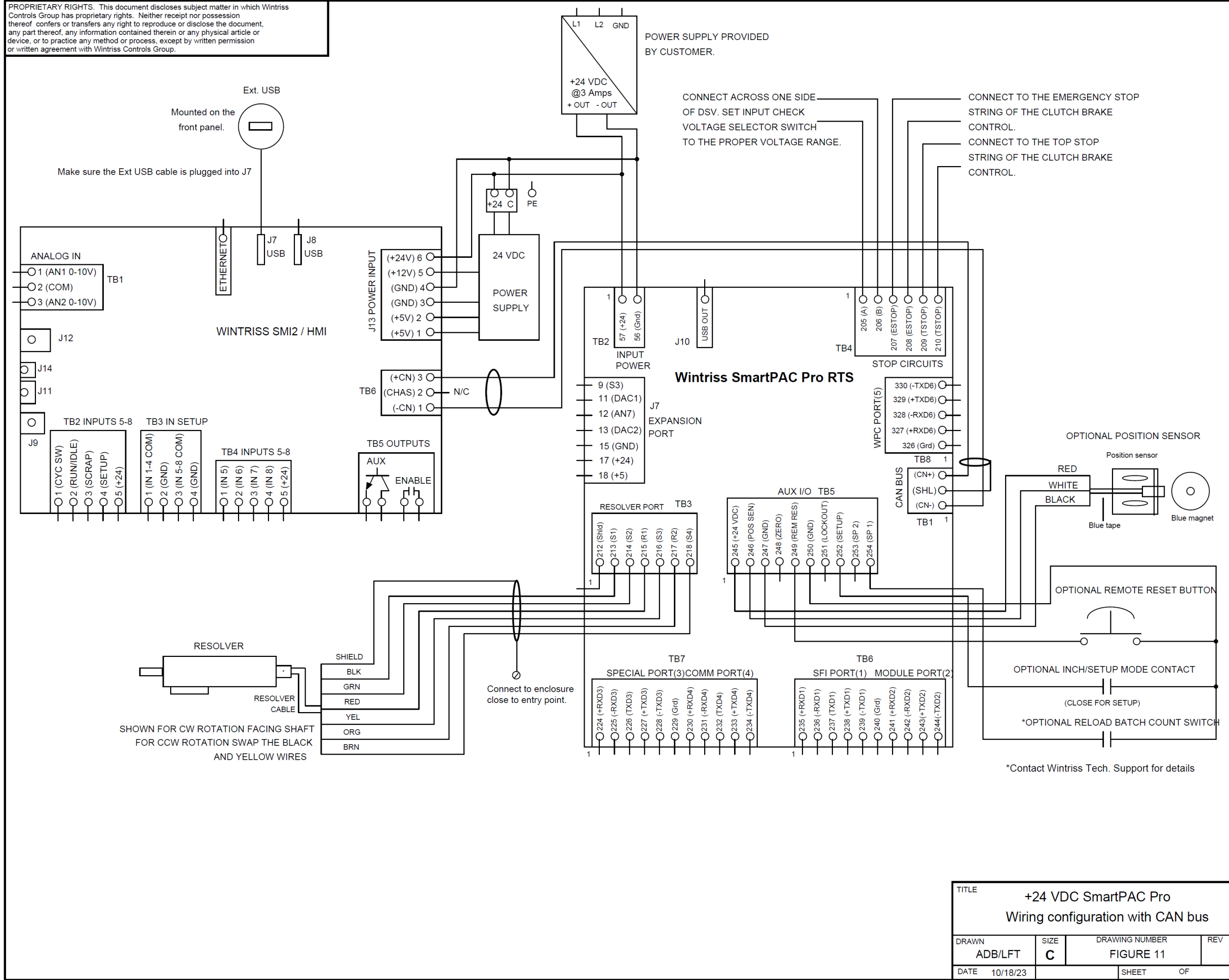

| | | | |
|-----------------------------------|----------|----------------|-----|
| TITLE | | | |
| +24 VDC SmartPAC Pro | | | |
| Wiring configuration with CAN bus | | | |
| DRAWN | SIZE | DRAWING NUMBER | REV |
| ADB/LFT | C | FIGURE 11 | |
| DATE | 10/18/23 | SHEET | OF |

PROPRIETARY RIGHTS. This document discloses subject matter in which Wintriss Controls Group has proprietary rights. Neither receipt nor possession thereof confers or transfers any right to reproduce or disclose the document, any part thereof, any information contained therein or any physical article or device, or to practice any method or process, except by written permission or written agreement with Wintriss Controls Group.

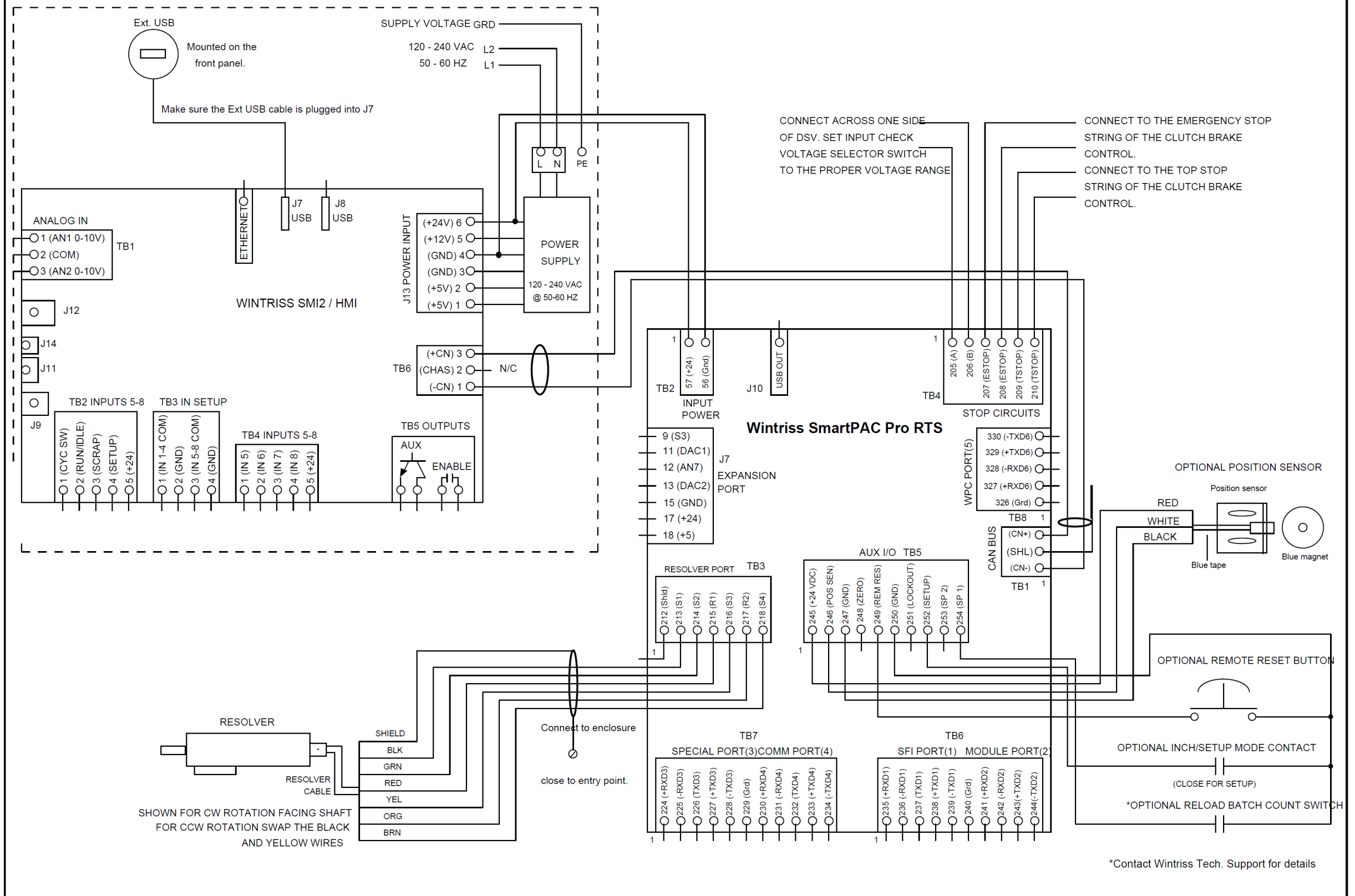

| | | | |
|-----------------------------------------------------------------------------|----------|----------------|-----|
| TITLE | | | |
| 120 - 240 VAC SmartPAC Pro with CAN bus and remote RTS wiring configuration | | | |
| DRAWN | SIZE | DRAWING NUMBER | REV |
| ADB/LFT | C | FIGURE 12 | |
| DATE | 10/18/23 | SHEET | OF |

